



OPERATORS MANUAL

5.5 EGCD 60HZ

5.0 EGCD 50HZ

MARINE DIESEL GENERATORS SINGLE PHASE

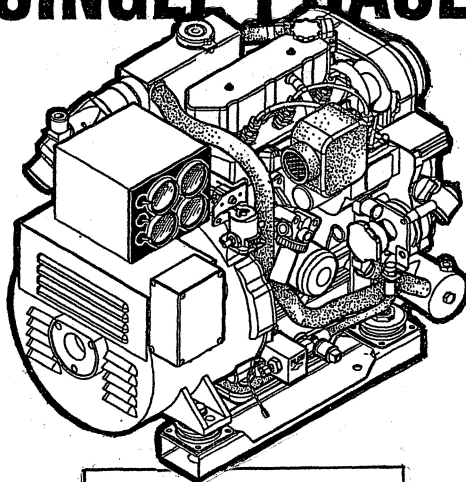

PUBLICATION NO. 056308

REVISION 0

JULY 2016



WESTERBEKE CORPORATION • 150 JOHN HANCOCK ROAD
MYLES STANDISH INDUSTRIAL PARK • TAUNTON MA 02780
WEBSITE: WWW.WESTERBEKE.COM



Member National Marine Manufacturers Association

**CALIFORNIA
PROPOSITION 65 WARNING**

Diesel engine exhaust and some of its constituents are known to the State of California to cause cancer, birth defects, and other reproductive harm.

⚠ WARNING:

Exhaust gasses contain Carbon Monoxide, an odorless and colorless gas. Carbon Monoxide is poisonous and can cause unconsciousness and death. Symptoms of Carbon Monoxide exposure can include:

- ***Dizziness***
- ***Throbbing in Temples***
- ***Nausea***
- ***Muscular Twitching***
- ***Headache***
- ***Vomiting***
- ***Weakness and Sleepiness***
- ***Inability to Think Coherently***

IF YOU OR ANYONE ELSE EXPERIENCE ANY OF THESE SYMPTOMS, GET OUT INTO THE FRESH AIR IMMEDIATELY. If symptoms persist, seek medical attention. Shut down the unit and do not restart until it has been inspected and repaired.



This WARNING DECAL is provided by WESTERBEKE and should be fixed to a bulkhead near your engine or generator.

WESTERBEKE also recommends installing CARBON MONOXIDE DETECTORS in the living/sleeping quarters of your vessel. They are inexpensive and easily obtainable at your local marine store.

SAFETY INSTRUCTIONS

INTRODUCTION

Read this safety manual carefully. Most accidents are caused by failure to follow fundamental rules and precautions. Know when dangerous conditions exist and take the necessary precautions to protect yourself, your personnel, and your machinery.

The following safety instructions are in compliance with the American Boat and Yacht Council (ABYC) standards.

PREVENT ELECTRIC SHOCK

⚠ WARNING: Do not touch AC electrical connections while engine is running, or when connected to shore power. Lethal voltage is present at these connections!

- Do not operate this machinery without electrical enclosures and covers in place.
- Shut off electrical power before accessing electrical equipment.
- Use insulated mats whenever working on electrical equipment.
- Make sure your clothing and skin are dry, not damp (particularly shoes) when handling electrical equipment.
- Remove wristwatch and all jewelry when working on electrical equipment.

PREVENT BURNS — HOT ENGINE

⚠ WARNING: Do not touch hot engine parts or exhaust system components. A running engine gets very hot!

- Monitor engine antifreeze coolant level at the plastic coolant recovery tank and periodically at the filler cap location on the water jacketed exhaust manifold, but only when the engine is COLD.

⚠ WARNING: Steam can cause injury or death!

- In case of an engine overheat, allow the engine to cool before touching the engine or checking the coolant.

PREVENT BURNS — FIRE

⚠ WARNING: Fire can cause injury or death!

- Prevent flash fires. Do not smoke or permit flames or sparks to occur near the carburetor, fuel line, filter, fuel pump, or other potential sources of spilled fuel or fuel vapors. Use a suitable container to catch all fuel when removing the fuel line, carburetor, or fuel filters.
- Do not operate with the air cleaner/silencer removed. Backfire can cause severe injury or death.
- Do not smoke or permit flames or sparks to occur near the fuel system. Keep the compartment and the engine/generator clean and free of debris to minimize the chances of fire. Wipe up all spilled fuel and engine oil.
- Be aware — diesel fuel will burn.

PREVENT BURNS — EXPLOSION

⚠ WARNING: Explosions from fuel vapors can cause injury or death!

- Follow re-fueling safety instructions. Keep the vessel's hatches closed when fueling. Open and ventilate cabin after fueling. Check below for fumes/vapor before running the blower. Run the engine compartment blower prior to starting, following the recommendation of the vessel builder.
- All fuel vapors are highly explosive. Use extreme care when handling and storing fuels. Store fuel in a well-ventilated area away from spark-producing equipment and out of the reach of children.
- Do not fill the fuel tank(s) while the engine is running.
- Shut off the fuel service valve at the engine when servicing the fuel system. Take care in catching any fuel that might spill. DO NOT allow any smoking, open flames, or other sources of fire near the fuel system or engine when servicing. Ensure proper ventilation exists when servicing the fuel system.
- Do not alter or modify the fuel system.
- Be sure all fuel supplies have a positive shutoff valve.
- Be certain fuel line fittings are adequately tightened and free of leaks.
- Make sure a fire extinguisher is installed nearby and is properly maintained. Be familiar with its proper use. Extinguishers rated ABC by the NFPA are appropriate for all applications encountered in this environment.

SAFETY INSTRUCTIONS

ACCIDENTAL STARTING

⚠ WARNING: Accidental starting can cause injury or death!

- Disconnect the battery cables before servicing the engine/generator. Remove the negative lead first and reconnect it last.
- Make certain all personnel are clear of the engine before starting.
- Make certain all covers, guards, and hatches are re-installed before starting the engine.

BATTERY EXPLOSION

⚠ WARNING: Battery explosion can cause injury or death!

- Do not smoke or allow an open flame near the battery being serviced. Lead acid batteries emit hydrogen, a highly explosive gas, which can be ignited by electrical arcing or by lit tobacco products. Shut off all electrical equipment in the vicinity to prevent electrical arcing during servicing.
- Never connect the negative (-) battery cable to the positive (+) connection terminal of the starter solenoid. Do not test the battery condition by shorting the terminals together. Sparks could ignite battery gases or fuel vapors. Ventilate any compartment containing batteries to prevent accumulation of explosive gases. To avoid sparks, do not disturb the battery charger connections while the battery is being charged.
- Avoid contacting the terminals with tools, etc., to prevent burns or sparks that could cause an explosion. Remove wristwatch, rings, and any other jewelry before handling the battery.
- Always turn the battery charger off before disconnecting the battery connections. Remove the negative lead first and reconnect it last when servicing the battery.

BATTERY ACID

⚠ WARNING: Sulfuric acid in batteries can cause severe injury or death!

- When servicing the battery or checking the electrolyte level, wear rubber gloves, a rubber apron, and eye protection. Batteries contain sulfuric acid which is destructive. If it comes in contact with your skin, wash it off at once with water. Acid may splash on the skin or into the eyes inadvertently when removing electrolyte caps.

TOXIC EXHAUST GASES

⚠ WARNING: Carbon monoxide (CO) is a deadly gas!

- Ensure that the exhaust system is adequate to expel gases discharged from the engine. Check the exhaust system regularly for leaks and make sure the exhaust manifold/water-injected elbow is securely attached.
- Be sure the unit and its surroundings are well ventilated. Run blowers when running the generator set or engine.
- Do not run the generator set or engine unless the boat is equipped with a functioning marine carbon monoxide detector that complies with ABYC A-24. Consult your boat builder or dealer for installation of approved detectors.
- For additional information, refer to ABYC TH-22 (educational information on Carbon Monoxide).

⚠ WARNING: Carbon monoxide (CO) is an invisible odorless gas. Inhalation produces flu-like symptoms, nausea or death!

- Do not use copper tubing in diesel exhaust systems. Diesel fumes can rapidly destroy copper tubing in exhaust systems. Exhaust sulfur causes rapid deterioration of copper tubing resulting in exhaust/water leakage.
- Do not install exhaust outlet where exhaust can be drawn through portholes, vents, or air conditioners. If the engine exhaust discharge outlet is near the waterline, water could enter the exhaust discharge outlet and close or restrict the flow of exhaust. Avoid overloading the craft.
- Although diesel engine exhaust gases are not as toxic as exhaust fumes from gasoline engines, carbon monoxide gas is present in diesel exhaust fumes. Some of the symptoms or signs of carbon monoxide inhalation or poisoning are:

Vomiting	Inability to think coherently
Dizziness	Throbbing in temples
Headache	Muscular twitching
Nausea	Weakness and sleepiness

AVOID MOVING PARTS

⚠ WARNING: Rotating parts can cause injury or death!

- Do not service the engine while it is running. If a situation arises in which it is absolutely necessary to make operating adjustments, use extreme care to avoid touching moving parts and hot exhaust system components.

SAFETY INSTRUCTIONS

- Do not wear loose clothing or jewelry when servicing equipment; avoid wearing loose jackets, shirts, sleeves, rings, necklaces or bracelets that could be caught in moving parts.
- Make sure all attaching hardware is properly tightened. Keep protective shields and guards in their respective places at all times.
- Do not check fluid levels or the drive belt's tension while the engine is operating.
- Stay clear of the drive shaft and the transmission coupling when the engine is running; hair and clothing can easily be caught in these rotating parts.

HAZARDOUS NOISE

 **WARNING: High noise levels can cause hearing loss!**

- Never operate an engine without its muffler installed.
- Do not run an engine with the air intake (silencer) removed.

 **WARNING: Do not work on machinery when you are mentally or physically incapacitated by fatigue!**

OPERATORS MANUAL

Many of the preceding safety tips and warnings are repeated in your Operators Manual along with other cautions and notes to highlight critical information. Read your manual carefully, maintain your equipment, and follow all safety procedures.

ENGINE AND GENERATOR INSTALLATIONS

Preparations to install an engine should begin with a thorough examination of the American Boat and Yacht Council's (ABYC) standards. These standards are a combination of sources including the USCG and the NFPA.

Sections of the ABYC standards of particular interest are:

- H-32 Ventilation for boats using diesel fuel
- H-33 Diesel Fuel Systems
- P-1 Installation of Exhaust Systems for Propulsion and Auxiliary Engines
- P-4 Marine Inboard Engines and Transmissions
- E-11 AC & DC Electrical Systems on Boats
- TA Batteries and Battery Chargers

All installations must comply with the Federal Code of Regulations (FCR).

ABYC, NFPA AND USCG PUBLICATIONS FOR INSTALLING MARINE ENGINES AND GENERATORS

Read the following ABYC, NFPA and USCG publications for safety codes and standards. Follow their recommendations when installing your UNIVERSAL engine

ABYC (American Boat and Yacht Council)
"Safety Standards for Small Craft"

Order From:

ABYC
613 Third Street, Suite 10
Annapolis, MD 21403
(410) 990-4460
www.abycinc.org

NFPA (National Fire Protection Association)
"Fire Protection Standard for Motor Craft"

Order From:

NFPA
1 Batterymarch Park
P.O. Box 9101
Quincy, MA 02269-9101

USCG (United States Coast Guard)
"CFR 33 AND CFR46"
Code of Federal Regulations

Order From:

U.S. Government Printing Office
Washington, D.C. 20404

INSTALLATION

When installing WESTERBEKE engines and generators it is important that strict attention be paid to the following information:

CODES AND REGULATIONS

Strict federal regulations, ABYC guidelines, and safety codes must be complied with when installing engines and generators in a marine environment.

SIPHON-BREAK

For installations where the exhaust manifold/water injected exhaust elbow is close to or will be below the vessel's waterline, provisions must be made to install a siphon-break in the raw water supply hose to the exhaust elbow. This hose must be looped a minimum of 20" above the vessel's waterline. *Failure to use a siphon-break when the exhaust manifold injection port is at or below the load waterline will result in raw water damage to the engine and possible flooding of the boat.*

If you have any doubt about the position of the water-injected exhaust elbow relative to the vessel's waterline under the vessel's various operating conditions, *install a siphon-break.*

NOTE: *A siphon-break requires periodic inspection and cleaning to ensure proper operation. Failure to properly maintain a siphon-break can result in catastrophic engine damage. Consult the siphon-break manufacturer for proper maintenance.*

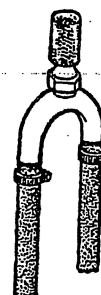

AVAILABLE FROM
YOUR WESTERBEKE
DEALER

SIPHON-BREAK WITH STAINLESS
LOOP

EXHAUST SYSTEM

The exhaust system's hose **MUST** be certified for marine use. Corrugated Marine Exhaust Hose is recommended. The use of this type of hose allows for extreme bends and turns without the need of additional fitting and clamps to accomplish these bends and turns. In this regard, a single length of corrugated exhaust hose can be used. The system **MUST** be designed to prevent the entry of water into the exhaust system under any sea conditions and at any angle of vessels heel.

A detailed Marine Installation Manual covering gasoline and diesel, engines and generators, is supplied with each unit. A pdf is available to download from our website at www.westerbeke.com.

TABLE OF CONTENTS

Parts Identification	2	Engine Adjustments	22
Introduction	3	Drive Belt Adjustment.....	22
Fuel, Engine Oil and Engine Coolant	5	Torquing the Cylinder Head Bolts	22
Preparations for Initial Start-Up	6	Valve Clearance Adjustment	23
Generator Control Panels	7	Spill Timing	24
Remote Panels	7	Testing Glow Plugs	25
Starting/Stopping Procedure	8	Testing Oil Pressure.....	25
Remote Panels	8	Engine Troubleshooting (Chart)	26
Generator Break-In Procedure	9	Electronic Governor	26
Daily Routine	9	Troubleshooting Gauges.....	27
Safety Shutdown Switches	10	Alternator Testing	29
Maintenance Schedule (Chart)	11	Battery Circuit	31
Fuel System	13	Wiring Diagram #056225	32
Cooling System	14	Wiring Schematic #056225	33
Fresh Water Cooling Circuit.....	15	Remote Panel Wiring Diagram	34
Changing the Coolant.....	15	Engine/Generator Specifications	35
Thermostat	16	Generator Information	36
Raw Water Intake Strainer	16	Generator Single Phase	37
Raw Water Cooling System	17	Circuit Breaker	37
Heat Exchanger	17	Internal Wiring Schematic.....	37
Raw Water Pump.....	17	Single Exciter Model	38
Engine Lubricating Oil	18	Dual Exciter Model	39
Engine Oil Change	18	Shore Power Connections	39
Remote Oil Filter (optional).....	19	Integral Controller	40
Starter Motor	20	Battery Charging Circuit	40
Troubleshooting.....	20	Optional Water Heater	41
		Installation	41
		Optional Power Take-Off	43
		Suggested Spares	44

EGTD PARTS IDENTIFICATION

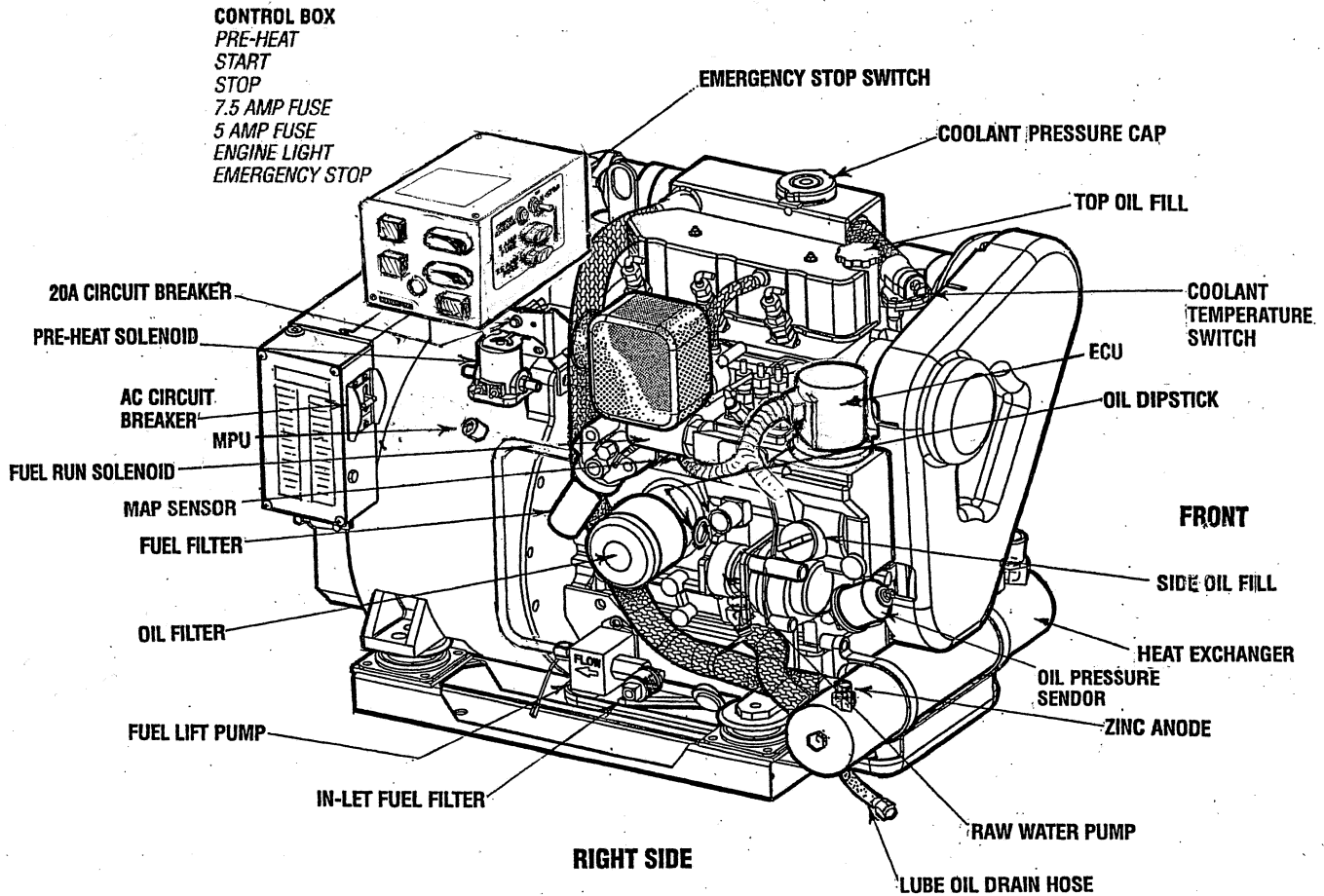
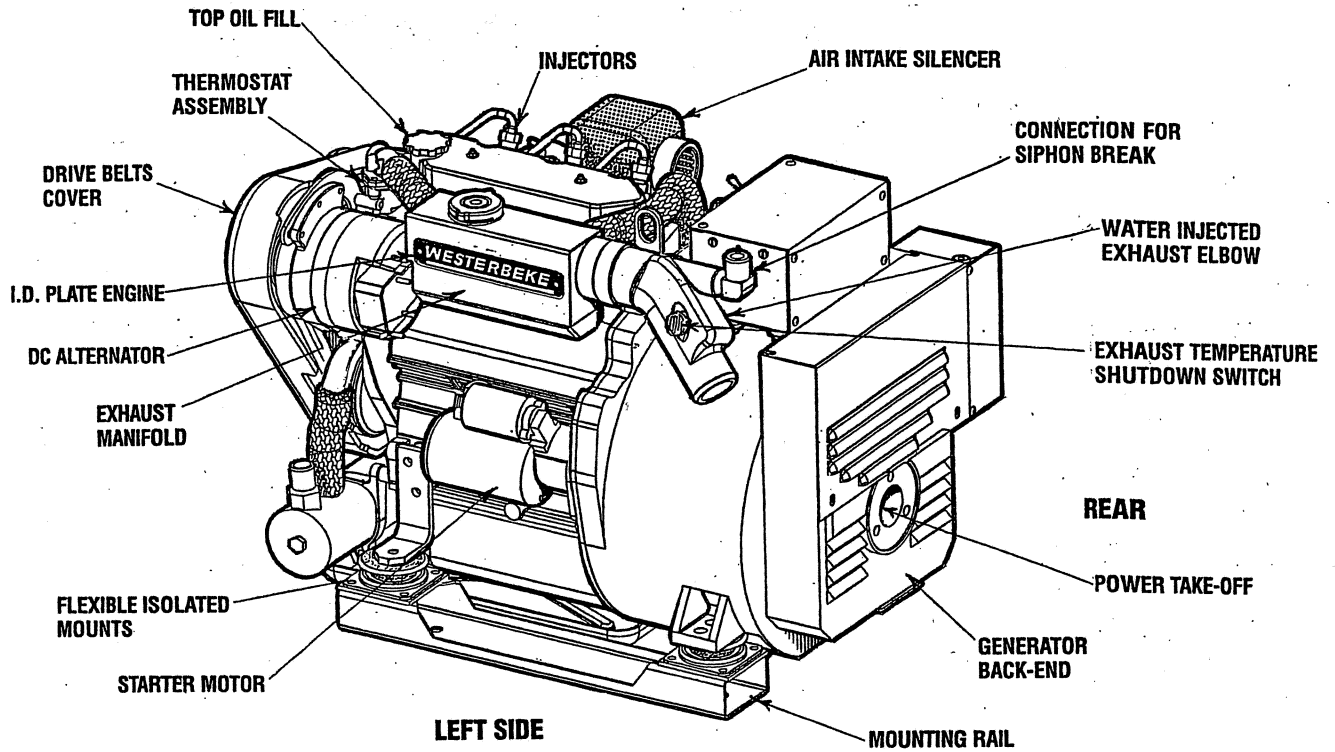

INTRODUCTION

This WESTERBEKE Diesel Generator is a product of WESTERBEKE's long years of experience and advanced technology. We take great pride in the superior durability and dependable performance of our engines and generators. Thank you for selecting WESTERBEKE.

In order to get the full use and benefit from your generator it is important that you operate and maintain it correctly. This manual is designed to help you do this. Please, read this manual carefully and observe all the safety precautions throughout. Should your generator require servicing, contact your nearest WESTERBEKE dealer for assistance.

This is your operators manual. A parts catalog is also provided and a technical manual is available from your WESTERBEKE dealer. If you are planning to install this equipment contact your WESTERBEKE dealer for WESTERBEKE'S installation manual.

WARRANTY PROCEDURES

Your WESTERBEKE Warranty is included in the documentation package supplied with this product. It includes a Warranty Registration Card that can be filled out and mailed in or you can register your warranty on our website: www.westerbeke.com. You should receive a Customer Identification Card after registering your warranty within 60 days. If you do not, please contact the factory having available the unit's model designation, engine serial number and date you purchased the unit.

Customer Identification Card



Customer Identification
MR. GENERATOR OWNER
MAIN STREET
HOMETOWN, USA
Model: Serial #
Expires:

PRODUCT SOFTWARE

Product software, (tech data, parts lists, manuals, brochures and catalogs), provided from sources other than WESTERBEKE are not within WESTERBEKE's control.

WESTERBEKE CANNOT BE RESPONSIBLE FOR THE CONTENT OF SUCH SOFTWARE, MAKES NO WARRANTIES OR REPRESENTATIONS WITH RESPECT THERETO, INCLUDING ACCURACY, TIMELINESS OR COMPLETENESS THEREOF AND WILL IN NO EVENT BE LIABLE FOR ANY TYPE OF DAMAGE OR INJURY INCURRED IN CONNECTION WITH OR ARISING OUT OF THE FURNISHING OR USE OF SUCH SOFTWARE.

WESTERBEKE customers should also keep in mind the time span between printings of WESTERBEKE product software and the unavoidable existence of earlier WESTERBEKE manuals. In summation, product software provided with WESTERBEKE products, whether from WESTERBEKE or other suppliers, must not and cannot be relied upon exclusively as the definitive authority on the respective product. It not only makes good sense but is imperative that appropriate representatives of WESTERBEKE or the supplier in question be consulted to determine the accuracy and currentness of the product software being consulted by the customer.

NOTES, CAUTIONS AND WARNINGS

As this manual takes you through the operating procedures, maintenance schedules, and troubleshooting of your marine engine, critical information will be highlighted by NOTES, CAUTIONS, and WARNINGS. An explanation follows:

NOTE: *An operating procedure essential to note.*

CAUTION: *Procedures, which if not strictly observed, can result in the damage or destruction of your engine.*

WARNING: *Procedures, which if not properly followed, can result in personal injury or loss of life.*

ENGINE OPERATION

This engine is certified to operate at 1800 rpm (60 Hertz) in the United States. Operating this engine at 1500 rpm (50 Hertz) in the United States may be a violation of Federal Law.



INTRODUCTION

SERIAL NUMBER LOCATION

The engine and generator serial numbers and model numbers are located on a decal on the generator housing. Take the time to enter this information on the illustration of the nameplate shown below, as this will provide a quick reference when seeking technical information and/or ordering repair parts.

SPECIFICATION	50 HZ.	60 HZ.
MODEL		
RPM		
KW		
KVA		
VOLTS		
AMPS		
ENG. HP		
ENG. SER. NO.		
GEN. SER. NO.		
PF/PHASE	/	
WIRES		
RATING		
INSUL. CLASS		
TEMP. RISE		
BATTERY		
C.I.D.		

The engine serial number can also be found stamped into the engine block just above the injection pump. The generator serial number is stamped into the generator housing on the flat surface on the left side of the generator.



An identification plate on the engine manifold also displays the engine model and serial number.

NOTE: A carbon monoxide warning decal has been provided by WESTERBEKE. Affix this decal in a visible position in the engine room.

UNDERSTANDING THE DIESEL ENGINE

The diesel engine closely resembles the gasoline engine, since the mechanism is essentially the same. The cylinders are arranged above a closed crankcase; the crankshaft is of the same general type as that of a gasoline engine, and the diesel engine has the same type of valves, camshaft, pistons, connecting rods and lubricating system.

Therefore, to a great extent, a diesel engine requires the same preventive maintenance as a gasoline engine. The most important factors are proper ventilation and proper maintenance of the fuel, lubricating and cooling systems. Replacement of fuel and lubricating filter elements at the time periods specified is a must, and frequent checking for contamination (that is water, sediment, etc.) in the fuel system is also essential. Another important factor is the use of the same brand of high detergent diesel lubrication oil designed specifically for diesel engines.

The diesel engine does differ from the gasoline engine, however, in its method of handling and firing of fuel. The carburetor and ignition systems are replaced by a single component – the fuel injection pump – which performs the function of both.

ORDERING PARTS

Whenever replacement parts are needed, always provide the generator model number, engine serial number, and generator serial number as they appear on the silver and black nameplate located on the generator end. You must provide us with this information so we may properly identify your generator set. In addition, include a complete part description and part number for each part needed (see the separately furnished Parts List). Insist upon WESTERBEKE packaged parts because *will fit* or generic parts are frequently not made to the same specifications as original equipment.

SPARES AND ACCESSORIES

Certain spares will be needed to support and maintain your WESTERBEKE engine. Your local WESTERBEKE dealer will assist you in preparing an inventory of spare parts. See the *SPARE PARTS* page in this manual. For engine accessories, see WESTERBEKE'S *ACCESSORIES* brochure.

FUEL, ENGINE OIL AND ENGINE COOLANT

FUEL

CAUTION: Use only No.2-D (SAE J313) diesel that has a Cetane rating of #45 or higher. Grade of diesel according to ASTM D975.

Care Of The Fuel Supply

Use only clean fuel! The clearance of the components in your fuel injection pump is very critical; invisible dirt particles which might pass through the filter can damage these finely finished parts. It is important to buy clean fuel, and keep it clean. The best fuel can be rendered unsatisfactory by careless handling or improper storage facilities. To assure that the fuel going into the tank for your engine's daily use is clean and pure, the following practice is advisable:

Purchase a well-known brand of fuel.

Install and regularly service a good, Coast Guard approved metal bowl type filter/water separator between the fuel tank and the engine.

ENGINE OIL

Use a well known brand of lubricating oil, with an API classification and SAE as listed in the SPECIFICATION pages of this manual

Change the oil and filter after the initial 50 hours of break-in operation. Then follow the oil and filter change intervals as specified in the MAINTENANCE SCHEDULE in this manual.

Westerbeke Corporation does not approve or disapprove of the use of synthetic oil. If synthetic oil is used, engine break-in must be performed using conventional oil. Oil change intervals must be as listed in the MAINTENANCE SCHEDULE section of this manual and the change intervals are not to be extended if synthetic oil is used.

NOTE: The information above supersedes all previous statements regarding synthetic oil.

ENGINE COOLANT

WESTERBEKE recommends a mixture of 50% antifreeze and 50% distilled water. Distilled water is free from the chemicals that can corrode internal engine surfaces.

The antifreeze performs double duty. It allows the engine to run at proper temperatures by transferring heat away from the engine to the coolant. It also lubricates and protects the cooling circuit from rust and corrosion. Use a good quality antifreeze that contains supplemental cooling additives (SCAs) that keep the antifreeze chemically balanced, crucial to long term protection.

Select a brand of antifreeze specified for diesel engines. Antifreeze specified for diesel engines contains a special additive to protect against cavitation erosion of the engine's cylinder walls.

Prestone and Zerex are two nationally known brands that offer antifreeze specifically for use in diesel engines.

Select the pre-mixed variety so that the correct mixture will always be added to the cooling system when needed.

Change the antifreeze mixture according to the MAINTENANCE SCHEDULE in this manual.

COOLANT RECOVERY TANK

A coolant recovery tank kit is supplied with each generator. The purpose of this recovery tank is to allow for engine coolant expansion and contraction during engine operation without the loss of coolant and without introducing air into the cooling system.

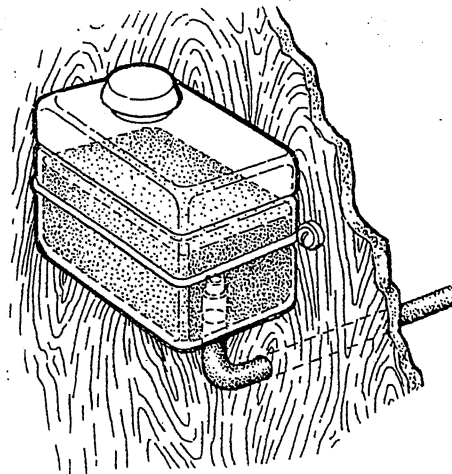

PREPARATIONS FOR INITIAL START-UP

PRESTART INSPECTION

Before starting your generator set for the first time or after a prolonged layoff, check the following items:

- Make certain the cooling water thru-hull is open.
- Check the engine oil level. Add oil to maintain the level at the full mark on the dipstick.
- Check the fuel supply and examine the fuel filter/separator bowls for contaminants.
- Check the DC electrical system. Inspect wire connections and battery cable connections.
- Check load leads for correct connection as specified in the wiring diagrams.
- Examine air inlet and outlet for air flow obstructions (SoundGuards).
- Be sure no other generator or utility power is connected to load lines.
- Be sure that in power systems with a neutral line that the neutral is properly grounded (or ungrounded) as the system requires, and that the generator neutral is properly connected to the load neutral. In single phase systems an incomplete or open neutral can supply the wrong line-to-neutral voltage on unbalanced loads.
- Visually examine the unit. Look for loose or missing parts, disconnected wires, unattached hoses, and check threaded connections. Search for any gasoline leaks.

CAUTION: When starting the generator, it is recommended that all AC loads, especially large motors, be switched OFF until the engine has come up to speed and, in cold climates, starts to warm up. This precaution will prevent damage caused by unanticipated operation of the AC machinery and will prevent a cold engine from stalling.

- Check the coolant level in both the plastic recovery tank and at the manifold.

NOTE: After the initial running of the generator, the air in the engine's cooling system will be purged to the coolant recovery tank. Open the air bleed petcock to ensure that the cooling system is purged of air. After shutdown and after the engine has cooled, the coolant from the recovery tank will be drawn into the engine's cooling system to replace the purged air.

Before subsequent operation of the generator, the engine's manifold should be topped off, and the coolant recovery tank may need to be filled to the MAX level.

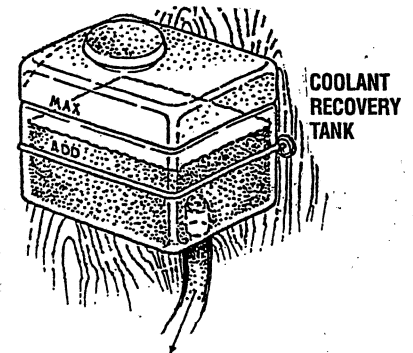
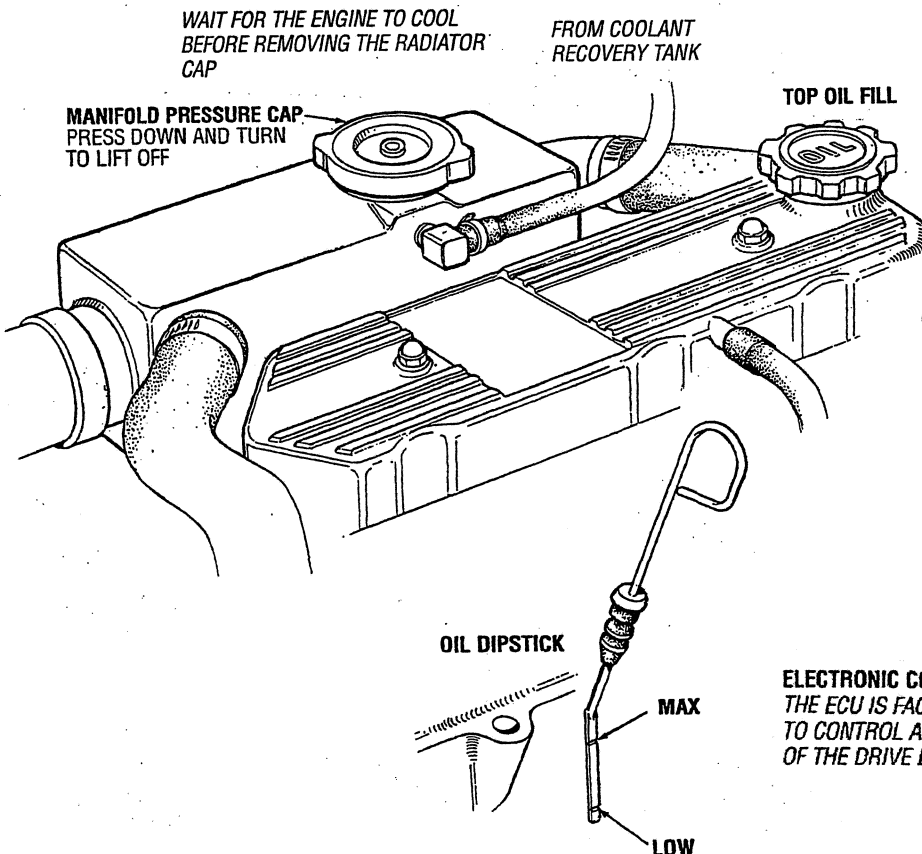

TO NIPPLE AT MANIFOLD PRESSURE CAP

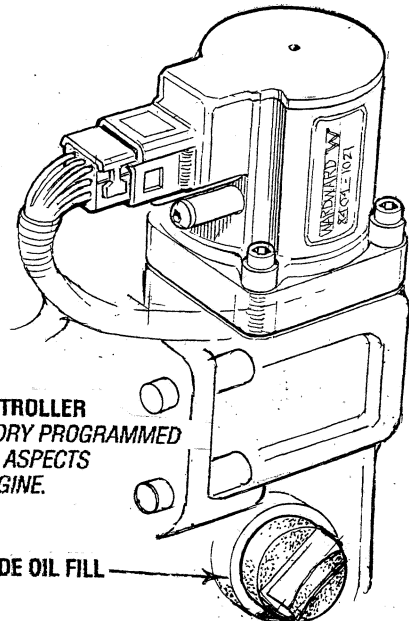

GENERATOR INSTRUMENT CONTROL PANEL

ENGINE MOUNTED

DESCRIPTION

The Generators Instrument Control Box contains a compact gauge package, control rocker switches, circuit fuses, check engine light, emergency stop toggle switch and a recording hourmeter. These components are described below.

The 8 pin connector that is on the back of the Control Box is used to connect an optional remote start/stop panel or a second instrument panel.

When an optional panel is connected, the 8 pin connector with jumper should be kept for future needs when troubleshooting. Secure it to the lifting eye.

COOLANT TEMPERATURE: Engine coolant (water) temperature should normally indicate: 175° to 195°F (80° to 90°C)

ENGINE OIL PRESSURE: Oil Pressure (psi) may fluctuate depending on the generator load but should range between 35 to 55 psi.

DC VOLTS: Indicates the amount the battery is being charged and should show 13V to 14V.

HOURLMETER: Registers elapsed time and is used as a guide for when to perform scheduled maintenance.

PREHEAT: The PREHEAT rocker switch serves two purposes: activates the preheat circuit and activated the K2 Run Relay. This supplies power to the DC alternator R, fuel pump, ECU, Instrument panel, K3 Fault Relay pin #87 and Start toggle switch.

START: The START rocker switch when pressed activates the K1-Start Relay which activates the starter motor.

STOP: The STOP rocker switch when pressed and held, opens the DC circuit supplying power to the K2 Run Relay. De-activating it and shutting down the engine drive.

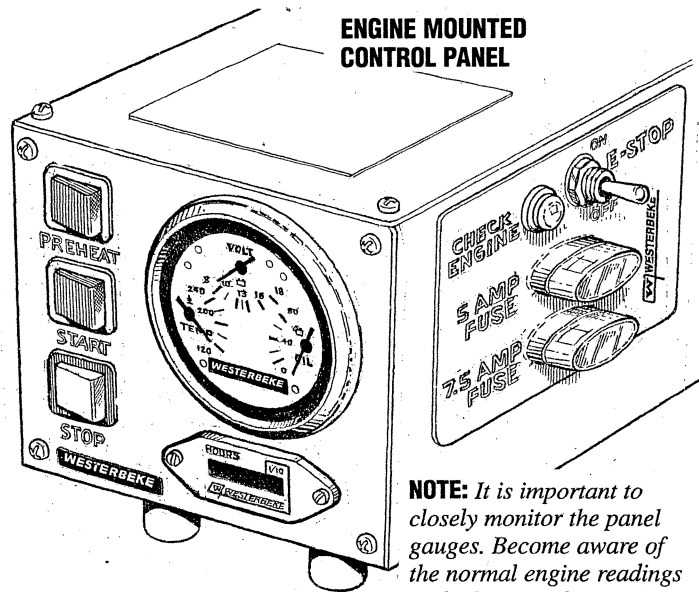

NOTE: It is important to closely monitor the panel gauges. Become aware of the normal engine readings and take immediate action if these readings start to vary.

FUSES: The control box has two automotive type fuses. A 5 amp fuse protects the ECU and a 7.5 amp to protect the control circuit and instrument panel.

CHECK ENGINE LIGHT: The CHECK ENGINE LED will illuminate if the engine shuts down. (Refer to the Safety Shutdown in this manual).

EMERGENCY STOP: The EMERGENCY stop toggle switch (Normally Closed) is located at the side of the control box. When depressed, it will open the DC circuit to the control box. This switch can be used when servicing the unit to prevent an unwanted start.

REMOTE PANEL PLUG IN: A plug on the side on the control box will allow for the remote mounting of the remote instrument panel or the remote stop/start panel.

STARTING/STOPPING PROCEDURE

ENGINE MOUNTED INSTRUMENT CONTROL PANEL

PREHEAT: Depress the PREHEAT rocker switch for approximately 5-10 seconds. Then with the PREHEAT rocker still depressed, depress the START rocker.

START: With a remote panel, observe the oil and DC voltmeter gauges. When the oil and voltmeter start to register a reading, release the START rocker. With a panel mounted on the generator, release the START rocker. Continue to hold the PREHEAT rocker switch depressed until the oil pressure reaches 10 psi. Then release the PREHEAT rocker switch.

Once the generator has started, observe the meter readings on the instrument panel. Ensure that raw water is being discharged with the exhaust. Apply a light amperage load on the generator and allow it to warm up to 140°F, then apply your higher amperage loads as needed.

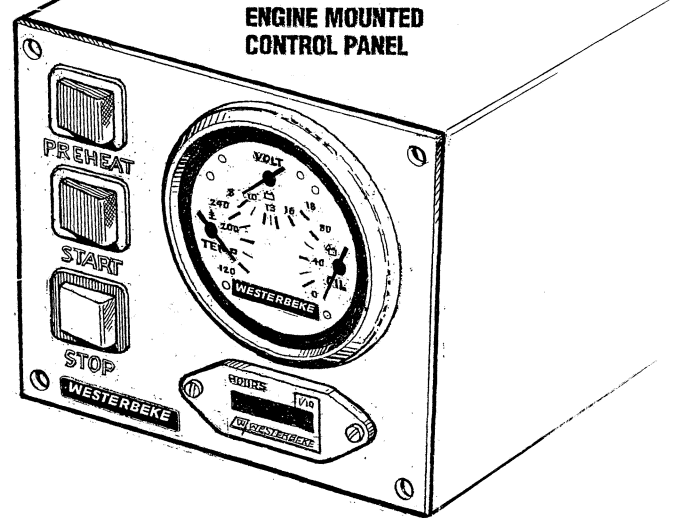

FAILURE TO START: Should the engine not start after the START rocker has been depressed for 5-10 seconds, release both rocker switches and wait 30 seconds and repeat the above start procedure. Preheat a few seconds longer. Never run the starter continuously for more than 20-25 seconds.

STOPPING: To stop the generator, depress the STOP rocker switch and hold it depressed. With a remote panel, observe the oil pressure. When it drops to zero, release the STOP rocker switch. With the panel mounted on the generator, release the STOP rocker switch when the generator comes to a complete stop.

REMOTE START/STOP PANEL

The Remote Start/Stop Panel has the same three rocker switches as the Instrument Control Panel. Their function is the same. This panel has a RELEASE STARTER LED. This LED will illuminate when the PREHEAT is depressed. When this panel is remote mounted, this LED will indicate when the generator has started. When depressing the START rocker switch, this LED will dim. When the generator starts, the LED will brighten. This indicates to release the START rocker switch. The PREHEAT rocker switch is held depressed for about 4-5 seconds to allow the oil pressure to reach 10 psi, then release it.

For the REMOTE STOP/START PANEL wiring diagram and wiring harness, refer to the Table of Contents.

REMOTE STOP/START PANEL

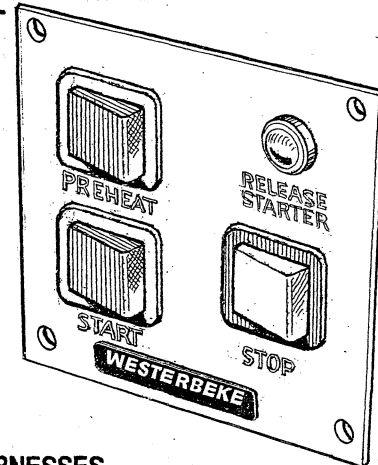

EXTENSION HARNESSES

PN. 056236 EG DIESEL (8 PIN) -15 feet
PN. 056235 EG DIESEL (8 PIN) -30 feet

GENERATOR BREAK-IN PROCEDURE

DESCRIPTION

Although your engine has experienced a minimum of one hour of test operations at the factory to make sure accurate assembly procedures were followed and that the engine operated properly, a break-in time is required. The service life of your engine is dependent upon how the engine is operated and serviced during its initial hours of use.

Breaking-in a new engine basically involves seating the piston rings to the cylinder walls. Excessive oil consumption and smoky operation indicate that the cylinder walls are scored, which is caused by overloading the engine during the break-in period.

Your new engine requires approximately 50 hours of initial conditioning operation to break in each moving part in order to maximize the performance and service life of the engine. Perform this conditioning carefully, keeping in mind the following:

Start the engine according to the *STARTING PROCEDURE* section. Run the engine while checking that all systems (raw water pump, oil pressure, battery charging) are functioning.

After the first 10 hours of the generators operation, the load can be increased to the full-load rated output, then periodically vary the load.

Avoid overload at all times. An overload is signaled by a smoky exhaust with reduced output voltage and frequency. Monitor the current being drawn from the generator and keep it within the generators' rating. Since the generator operates at 1800 rpm to produce 60 hertz, or at 1500 to produce 50 hertz, control of the generators engine break-in is governed by the current drawn from the generator.

NOTE: Be aware of motor starting loads and the high current drawn required for starting motors. This starting amperage draw can be 3 to 5 times normal running amperage. See *GENERATOR INFORMATION* in this manual.

GENERATOR ADJUSTMENTS

Once the generator has been placed into operation, there may be the need for a AC no-load voltage adjustment before or at the 50 hour break-in service. (see Generator Information).

AFTER START-UP

Once the generator has been started, check for proper operation and then encourage a fast warm-up. Run the generator between 20% and 60% of full load for the first 10 hours.

THE DAILY ROUTINE

CHECK LIST

Follow this checklist each day before starting your generator.

- Check that all generator circuit breakers (power panel) are in the off position before starting.
- Record the hourmeter reading in your log (engine hours relate to the maintenance schedule).
- Visually inspect the engine for fuel, oil, or water leaks.
- Check the oil level (dipstick).
- Check the coolant level in the coolant recovery tank.
- Check your fuel supply.
- Check the starting batteries (weekly).
- Check the drive belt for wear and proper tension (weekly)

CHECK WITH THE ENGINE RUNNING.

- Check for abnormal noise such as knocking, vibration and blow-back sounds.
- Confirm exhaust smoke:
When the engine is cold – White Smoke.
When the engine is warm – almost Smokeless.
When the engine is overloaded – some Black Smoke.

NOTE: Some unstable running may occur in a cold engine. This condition should abate as normal operating temperature is reached and loads are applied.

CAUTION: Do not operate the generator for long periods of time without a load being placed on the generator.

STOPPING THE GENERATOR

Remove the AC amperage loads from the generator one at a time. Allow the generator to run for 3 – 5 minutes to stabilize the operating temperatures. Then depress the STOP switch and hold depressed until the generator comes to a complete STOP.

NOTE: This engine is certified to operate at 1800 rpm (60 Hz) in the United States. Operating this engine at 1500 rpm (50 Hz) in the United States may be a violation of Federal Law.

SAFETY SHUTDOWN SWITCHES

CHECK ENGINE LED

SAFETY SHUTDOWN SWITCHES/SENSORS

The engine is protected by three safety shutdown switches. Should a shutdown occur due to one of these switches, the **Check Engine LED** will illuminate. The cause should be determined and corrected. The ECU must be cleared of this fault by turning off the 20 amp DC breaker and turning it back ON in order to start the engine.

High Water Temperature Switch

A high water temperature switch is located at the thermostat housing. Normally closed, this switch, should the fresh water coolant's operating temperature reach approximately 210°F (99°C), will open and interrupt the DC voltage thereby shutting off the engine. This switch resets at 195°F (107°C).

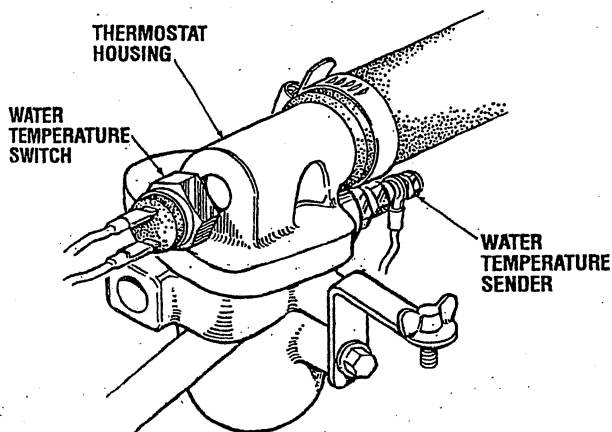

Low Oil Pressure Switch

A low oil pressure shutdown switch is located off the engine's oil gallery. Normally open in a static state, this switch's sensor monitors the engine's oil pressure. Should the engine's oil pressure fall to 5-10psi, this switch will open interrupting the DC voltage thereby shutting off the engine.

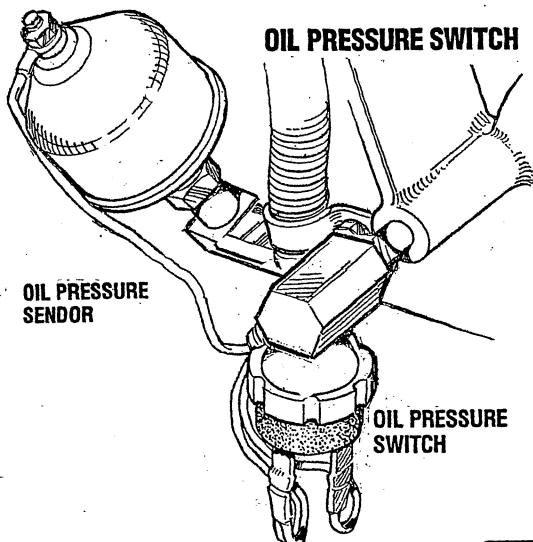

High Exhaust Temperature Switch

An exhaust temperature switch is located on the exhaust elbow. Normally closed, this switch will open and interrupt the DC voltage (shutting off the engine) should the switch's sensor indicate an excessive exhaust temperature (an inadequate supply of raw water causes high exhaust temperatures). This switch opens at 260°-270°F (127°-132°C). This switch resets at approximately 225°F (107°C).

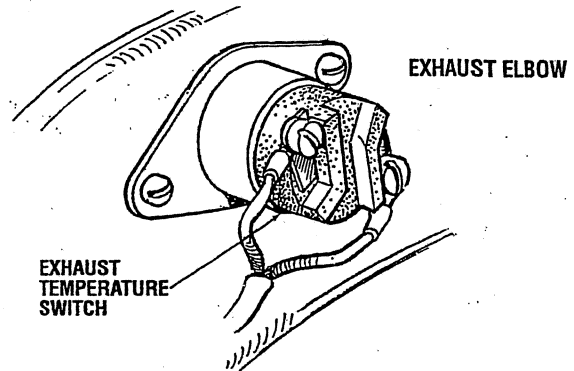

Engine Circuit Breaker

The generator's engine is protected by an engine mounted manual reset circuit breaker (20 amps DC). Excessive current draw or electrical overload anywhere in the instrument panel wiring or engine wiring will cause the breaker to trip. In this event, the generator will shutdown because the open breaker interrupts the DC circuit. If this should occur, check and repair the source of the problem. After repairing the fault, reset the breaker and restart the generator.

OVERSPEED SHUTDOWN

The unit's ECU is monitoring the engine speed via a signal from the MPU (Magnetic Pick-Up) positioned over the flywheel's ring gear teeth. Should the engine speed reach 2200 rpm (73 hertz), the ECU will shut the engine down and the **Check Engine LED** will illuminate.

MAINTENANCE SCHEDULE

⚠ WARNING: *Never attempt to perform any service while the engine is running. Wear the proper safety equipment such as goggles and gloves, and use the correct tools for each job. When servicing/replacing DC components, turn off the DC circuit breaker on the control panel, or turn off the battery switch.*

SCHEDULED MAINTENANCE

EXPLANATION OF SCHEDULED MAINTENANCE

Maintenance procedures are all detailed in this manual.

DAILY CHECK BEFORE START-UP

Coolant Level	Check at recovery tank, if empty, check at manifold. Add coolant if needed.
Engine Oil Level	Oil level should indicate between MAX and LOW on dipstick. Do not overfill!
Fuel/Water Separator (owner installed)	Check for water and dirt in fuel. Drain filter if necessary. Replace filter every 250 operating hours or once a year.
Fuel Supply	Use properly filtered #2 diesel with a Cetane rating of #45 or higher. Check that there is adequate fuel for the vessel's needs.
Visual Inspection of Engine	Check for fuel, oil and water and exhaust leaks. Check that the water injected exhaust elbow securing v-clamp is tight. No exhaust leaks around the elbow. Inspect wiring and electrical connections. Look for loose bolts/hardware and correct as needed.
Drive Belts	Inspect for frayed edges. Belts must be tight.

INITIAL 50 HOURS OF OPERATION

Engine Oil and Filter	Initial engine oil and filter change at 50 hours.
*Exhaust System	Check security of water injected exhaust elbow to exhaust manifold. Ensure there are no leaks.
*Valve Adjustment	Check adjustment of valves.
Inlet Fuel Filter	Remove and replace inlet fuel filter.
Fuel Filter	Remove and replace fuel filter and all sealing O-rings.
Generator	Check that AC connections are secure with no chafing.
Electronic Governor Control	Factory programmed - No adjustment.
Re-Torque Cylinder Head Hold Down Bolts	Re-torque bolts. Engine cold, then check the valve clearance adjustments.

EVERY 50 OPERATING HOURS OR MONTHLY

Drive Belt	Inspect for proper tension (3/8" to 1/2" deflection) and adjust if needed. Check belt for slipping, cracking and wear. Adjust tension or replace as needed. Replace cover.
Starting Batteries	Check electrolyte levels. Make sure cables and connections are in good order. Clean off corrosion if needed. Apply petroleum jelly to terminals for corrosion protection.
Electric Fuel Pump	Inspect for leaks, ensure fuel and electrical connections are clean and tight.
Zinc Anode	Inspect and clean zinc anode. Replace if necessary. Note the condition, then determine your own inspection schedule.

EVERY 100 OPERATING HOURS OR YEARLY

Engine Oil and Filter	Change engine oil and filter at 100 operating hours or yearly..
Air Intake and Filter (if applicable)	Keep air intake clear of obstructions. Clean air filter (if applicable)

*WESTERBEKE recommends this service be performed by an knowledgeable mechanic.

MAINTENANCE SCHEDULE

NOTE: Use the engine hourmeter gauge to log your engine hours or record your engine hours running time.

SCHEDULED MAINTENANCE

EXPLANATION OF SCHEDULED MAINTENANCE

EVERY 250 OPERATING HOURS OR YEARLY

*Exhaust Elbow/Exhaust System	Check the structural integrity of the water injected exhaust elbow casting. Check the integrity of the exhaust system attached to the elbow. All hose connections should be secure. No chaffing. No exhaust leaks. Hoses and muffler are in good serviceable condition. NOTE: An exhaust leak will cause exposure to diesel exhaust!
Fuel Filter and O-Rings	Remove and replace fuel filter and all sealing O-rings.
Inlet Fuel Filter	Remove and replace inlet fuel filter.
*Generator	Check that AC connections are clean and secure. Ensure wires have no chafing. See <i>GENERATOR INFORMATION</i> .
Hoses	Engine hoses should be firm and tight. Replace if hoses become spongy, brittle or delaminated. Check and tighten all hose clamps as needed.
Fuel Water Separator Filter	Inspect bowl for dirt or water in fuel. Drain and replace filter.
DC Alternator	Inspect wiring, connections should be tight. Alternator should be clean and free of corrosion. Check mounting bracket and alternator bolt. All should be tight.

EVERY 500 OPERATING HOURS OR FIVE YEARS

Raw Water Pump	Remove and disassemble the pump and inspect all parts: drive gear, pump shaft, wear plate and cover for wear and corrosion. Replace the impeller and gasket. Lubricate the impeller at re-assembly.
Coolant System	Drain, flush and re-fill the cooling system with appropriate antifreeze mix. Inspect the condition of the sealing gaskets of the pressure cap. Clean out coolant recovery tank and connecting hose.
*Valve Clearances	Adjust valves. (Incorrect valve clearance will result in poor engine performance.)
*Starter Motor	Check solenoid and motor for corrosion. Remove and lubricate. Clean and lubricate the starter motor pinion drive
Fuel Injectors	Check and adjust injection opening pressure and spray conditions.
Re-Torque Cylinder Head Hold Down Bolts	Re-torque bolts. Engine cold, then check the valve clearance adjustments.
Pre-Heat Circuit	Check operation of preheat solenoid. Remove glow plugs, clean tips and check operation.

EVERY 1000 OPERATING HOURS OR OR EVERY FIVE YEARS

Heat Exchanger	Remove the heat exchanger for professional cleaning and pressure testing.
----------------	---

*WESTERBEKE recommends this service be performed by an knowledgeable mechanic.

FUEL SYSTEM.

DIESEL FUEL

Use No. 2-D (SAE J313) diesel that has a Cetane rating of #45 or higher grade of diesel according to ASTM D975. (DO NOT add any alcohol based additives.

FUEL FILTERS

The fuel injection pump and the fuel injectors are precisely manufactured and they must receive clean diesel fuel, free from water and dirt. To ensure this flow of clean fuel, the fuel must pass through at least two fuel filters, a fuel water separator and the engine's spin-on fuel filter. Visually inspect, clean, and change these filters according to the maintenance schedule in this manual.

FUEL WATER SEPARATOR

A primary fuel filter of the water separating type must be installed between the fuel tank and the engine to remove water and other contaminants from the fuel before they can be carried to the fuel system on the engine.

The owner/operator is responsible for making certain the fuel reaching the engine's injection equipment is free of impurities. This process is accomplished by installing and maintaining a proper fuel filter/water separator between the fuel tank and the generator/engine. Westerbeke recommends a 10 micron filter be used.

FUEL INJECTION PUMP

The fuel injection pump is the most important component of the diesel engine, requiring the utmost caution in handling. The fuel injection pump has been thoroughly bench-tested and the owner/operator is cautioned not to attempt to service it. If it requires servicing, remove it and take it to an authorized fuel injection pump service facility. Do not attempt to disassembly and repair it.

FUEL LIFT PUMP

Periodically check the fuel connections to and out of the pump and make sure that no leakage is present and that the fittings are tight and secure. The DC ground connection at one of the pump's mounting bolts should be clean and well secured by the mounting bolt to ensure proper pump operation.

When energized thru the preheat circuit, the fuel lift pump will purge air from the fuel system and provide a continuous flow of fuel as the engine is running.

INLET FUEL FILTER

To ensure clean fuel into the fuel lift pump, there is a small in-line fuel filter connected to the fuel lift pump elbow. This filter should be replaced every 250 hours of operation.

ENGINE FUEL FILTER

Periodically check the fuel connections and the bowl for leakage. Replace the filter element after the first 50 hours then follow the *MAINTENANCE SCHEDULE*.

Changing/cleaning the filter element

1. Shut off the fuel supply.
2. Unscrew the retainer ring that holds the filter bowl to the housing and allow the bowl to come away from the housing,
3. Remove and replace the filter element and clean the bowl.
4. Replace the sealing "O" ring and reassemble the bowl to the housing. Thread the retainer ring on carefully so as not to cross thread. When retainer contacts the "O" ring, tighten 1/4 - 1/2 turns by hand. Open the fuel supply and run the engine to inspect for leaks.

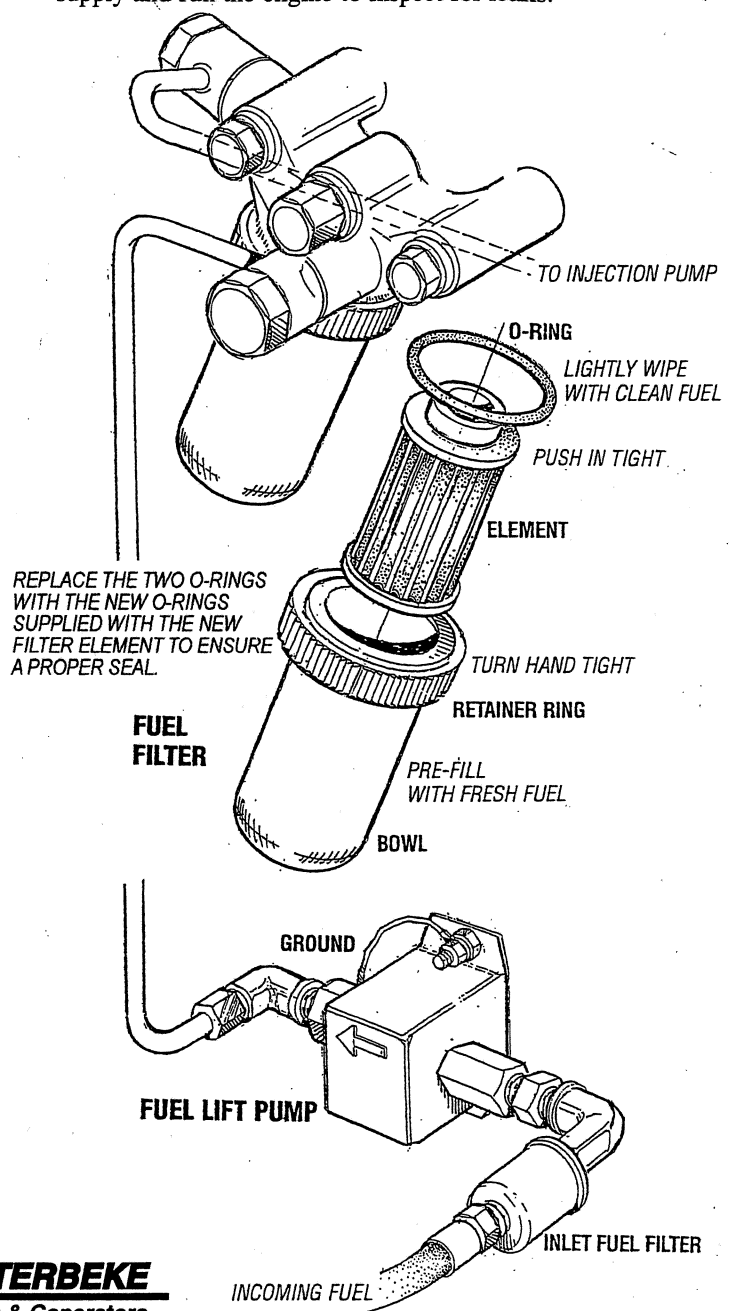

COOLING SYSTEM

DESCRIPTION

Westerbeke marine diesel engines are designed and equipped for fresh water cooling. Heat produced in the engine by combustion and friction is transferred to fresh water coolant which circulates throughout the engine. This circulating fresh water coolant cools the engine block, its internal moving parts, and the engine oil. The heat is transferred externally from the fresh water coolant to raw water by means of a heat exchanger, similar in function to an automotive radiator. Raw water flows through the tubes of the heat exchanger while

fresh water coolant flows around the tubes; engine heat transferred to the fresh water coolant is conducted through the tube walls to the raw water which is then pumped into the exhaust system where finally it is discharged overboard. In other words, the engine is cooled by fresh water coolant, this coolant is cooled by raw water, and the raw water carries the transferred heat overboard through the exhaust system. The fresh water coolant and raw water circuits are independent of each other. Using only fresh water coolant within the engine allows the cooling water passages to stay clean and free from harmful deposits.

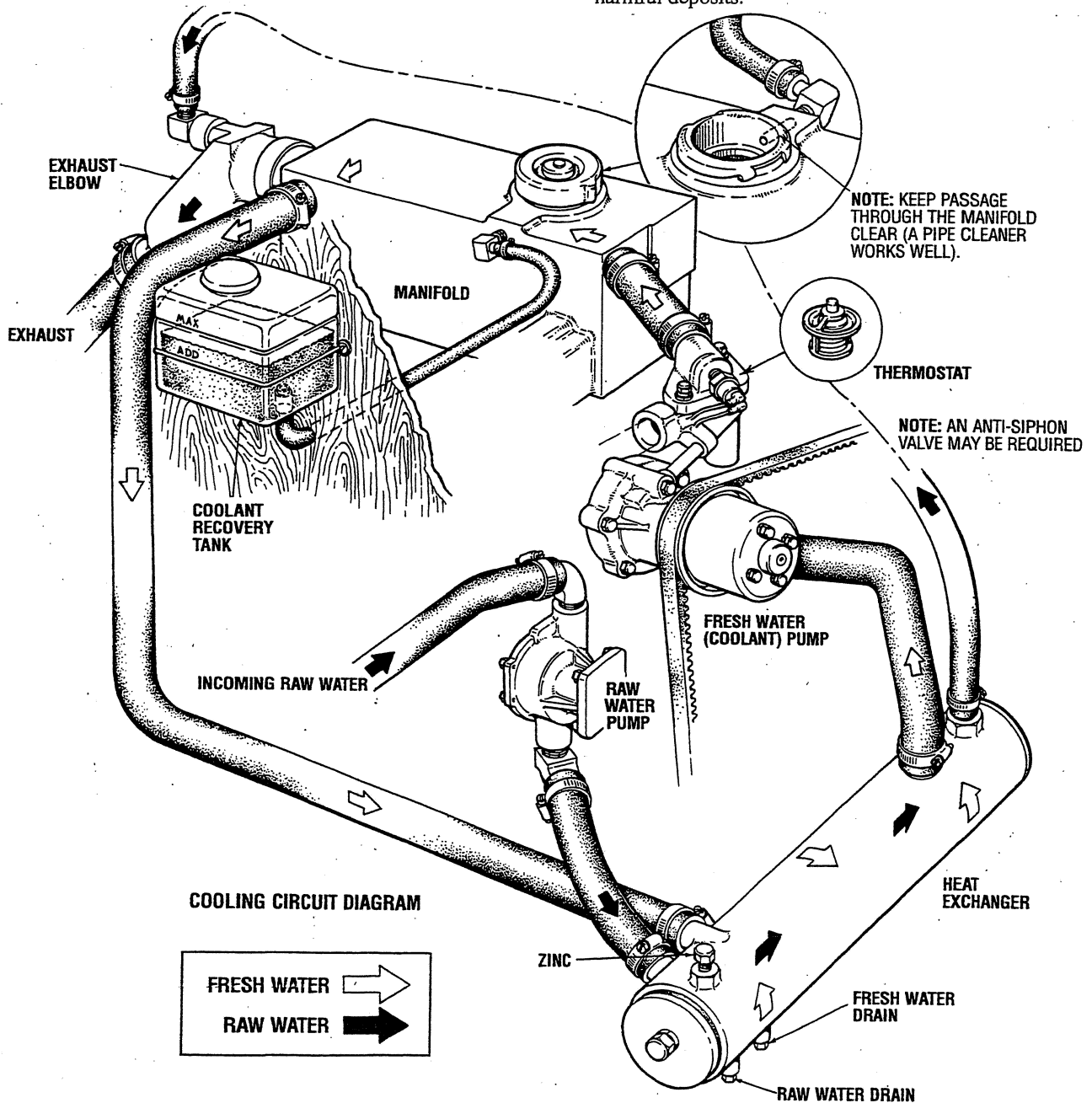

COOLING SYSTEM

FRESH WATER COOLING CIRCUIT

NOTE: Refer to the *ENGINE COOLANT* section for the recommended antifreeze and water mixture to be used as the fresh water coolant.

Fresh water coolant is pumped through the engine by a circulating pump, absorbing heat from the engine. The coolant then passes through the thermostat into the manifold, to the heat exchanger where it is cooled, and returned to the engine block via the suction side of the circulating pump.

When the engine is started cold, external coolant flow is prevented by the closed thermostat (although some coolant flow is bypassed around the thermostat to prevent the exhaust manifold from overheating). As the engine warms up, the thermostat gradually opens, allowing full flow of the engine's coolant to flow unrestricted to the external portion of the cooling system.

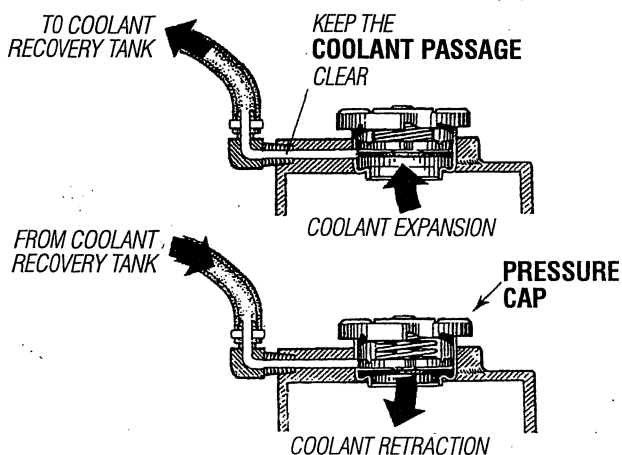

NOTE: Periodically check the condition of the manifold pressure cap. Ensure the upper and lower rubber seals are in good condition. Check to ensure the vacuum valve opens and closes tightly. Carry a spare cap. Check also to ensure the coolant passage is clear so coolant within the system is able to expand and contract to and from the coolant recovery tank.

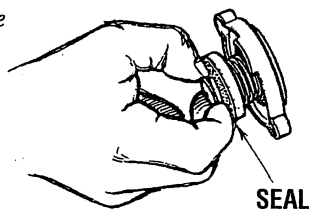

Coolant Recovery Tank

The coolant recovery tank allows for the expansion and contraction of the engine's coolant during engine operation without introducing air into the system. This recovery tank is provided with fresh water cooled models and with the fresh water coolant conversion kit and must be installed before operating the engine.

NOTE: This tank, with its short run of plastic hose, is best located at or above the level of the engine's manifold.

CHANGING COOLANT

The engine's coolant must be changed according to the *MAINTENANCE SCHEDULE*. If the coolant is allowed to become contaminated, it can lead to overheating problems.

CAUTION: Proper cooling system maintenance is critical; a substantial number of engine failures can be traced back to cooling system corrosion.

Drain the engine block's coolant by removing the hex head plug located just to the left of the oil filter. Also remove the hex drain plug on the lower side of the heat exchanger and remove the water jacketed exhaust manifold pressure cap to allow the coolant to drain properly. Flush the system with fresh water, then re-install the drain plugs and start the refill process.

WARNING: Beware of the hot engine coolant. Wear protective gloves.

Refilling the Coolant

After replacing the drain plugs, add new pre-mixed coolant through the filler neck on the water jacketed exhaust manifold until visible in the manifold. Start the engine.

Monitor the coolant in the manifold and add as needed. Fill the manifold to the filler neck and install the manifold pressure cap.

Remove the cap on the coolant recovery tank and fill with coolant mix to halfway between LOW and MAX and replace the cap. Run the engine and observe the coolant expansion flow into the recovery tank.

After checking for leaks, stop the engine and allow it to cool. Coolant should draw back into the cooling system as the engine cools down. Add coolant to the recovery tank if needed and check the coolant in the manifold. Clean up any spilled coolant.

COOLING SYSTEM

THERMOSTAT

A thermostat, located near the manifold at the front of the engine, controls the coolant temperature as the coolant continuously flows through the closed cooling circuit. When the engine is first started, the closed thermostat prevents coolant from flowing (some coolant is by-passed through a hole in the thermostat to prevent the exhaust manifold from overheating). As the engine warms up, the thermostat gradually opens. The thermostat is accessible and can be checked, cleaned, or replaced easily. Carry a spare thermostat and gasket

Replacing the Thermostat

Remove the cap screws and disassemble the thermostat housing as shown. When installing the new thermostat and gasket, apply a thin coat of sealant on both sides of the gasket before pressing it into place. Do not over-tighten the cap screws.

Run the engine and check for normal temperatures and that there are no leaks at the thermostat housing.

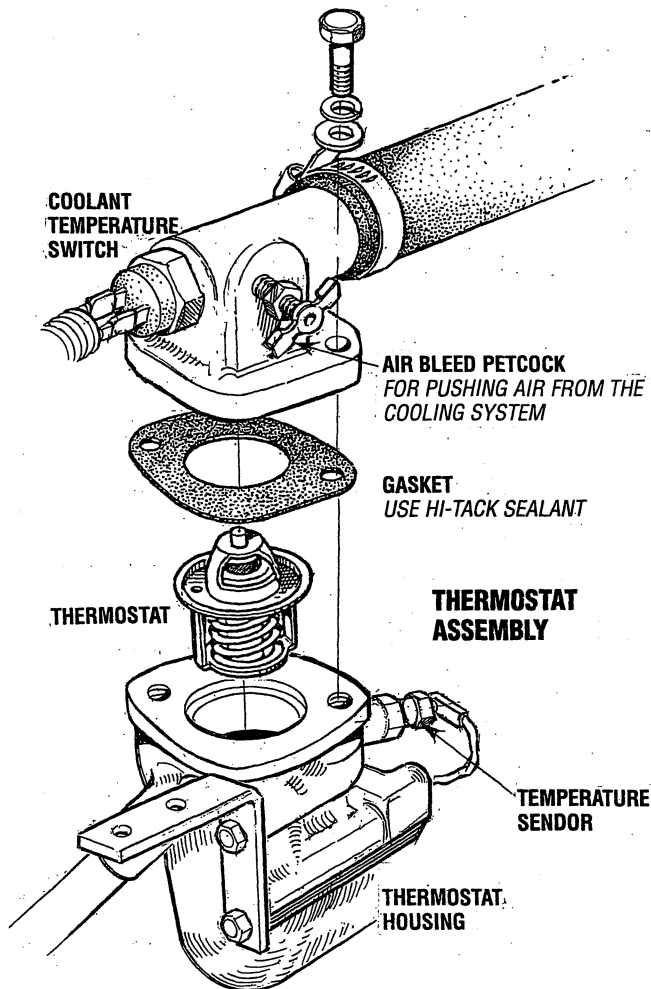

RAW WATER INTAKE STRAINER

NOTE: Always install the strainer at or below the waterline so the strainer will always be self-priming.

A clean raw water intake strainer is a vital component of the engine's cooling system. Include a visual inspection of this strainer when making your periodic engine check. The water in the glass should be clear.

Perform the following maintenance after every 100 hours of operation:

1. Close the raw water seacock.
2. Remove and clean the strainer filter.
3. Clean the glass.
4. Replace the washer if necessary.
5. Reassemble and install the strainer.
6. Open the seacock.
7. Run the engine and check for leaks.

NOTE: Also follow the above procedure after having run hard aground.

If the engine temperature gauge ever shows a higher than normal reading, the cause may be that silt, leaves or grass may have been caught up in the strainer, slowing the flow of raw water through the cooling system.

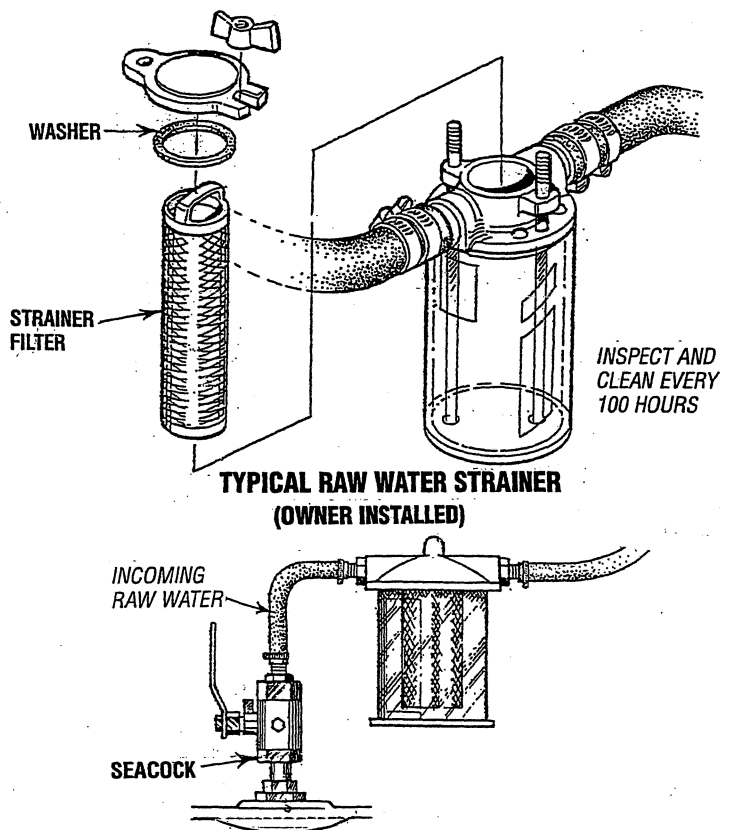

COOLING SYSTEM

RAW WATER COOLING CIRCUIT

The raw water flow is created by a positive displacement impeller pump. This pump draws water directly from the ocean, lake, or river from a thru-hull opening through a hose to the water strainer. The raw water passes from the strainer through the pump to the heat exchanger (through the heat exchanger tubes) where it cools the engine's circulating fresh water coolant. The raw water is then discharged into the water-injected exhaust elbow, mixing with, and cooling the exhaust gasses. This mixture of exhaust gas and raw water is driven through the stern tube and overboard.

HEAT EXCHANGER

Cool raw water flows through the inner tubes of the heat exchanger. As the engine coolant passes around these tubes, the heat of the internal engine is conducted to the raw water which is then pumped into the exhaust system and discharged. The engine coolant (now cooled) flows back through the engine and the circuit repeats itself.

NOTE: Operating in silty and/or tropical waters may require that a heat exchanger cleaning be performed more often than every 1000 hours.

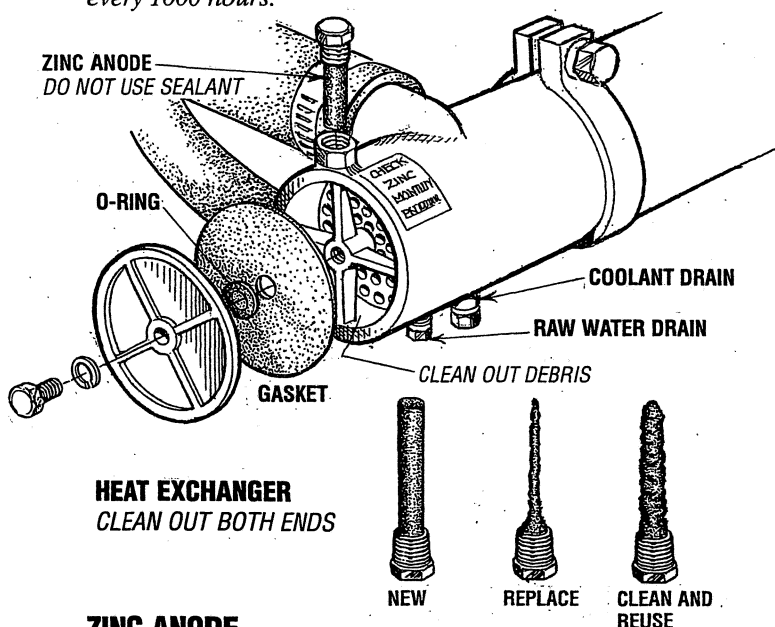

ZINC ANODE

A zinc anode, or pencil, is located in the raw water cooling circuit within the heat exchanger. The purpose of the zinc anode is to sacrifice itself to electrolysis action taking place in the raw water cooling circuit, thereby reducing the effects of electrolysis on other components of the system. The condition of the zinc anode should be checked monthly and the anode cleaned or replaced as required. Spare anodes should be carried on board.

NOTE: Electrolysis is the result of each particular installation and vessel location; not that of the engine.

NOTE: The threads of the zinc anodes are pipe threads and do not require sealant. Sealant should not be used as it may insulate the zinc from the metal of the heat exchanger housing preventing electrolysis action on the zinc.

RAW WATER PUMP

The raw water pump is a self-priming, rotary pump with a non-ferrous housing and a Neoprene impeller. The impeller has flexible blades which wipe against a curved cam plate within the impeller housing, producing the pumping action. **On no account should this pump be run dry.** There should always be a spare impeller and impeller cover gasket aboard (an impeller kit). Raw water pump impeller failures occur when lubricant (raw water) is not present during engine operation. Such failures are not warrantable, and operators are cautioned to make sure raw water flow is present at start-up. The raw water pump should be inspected periodically for broken or torn impeller blades. See *MAINTENANCE SCHEDULE*.

NOTE: Should a failure occur with the pumps internal parts (seals and bearings), it may be more cost efficient to purchase a new pump and rebuild the original pump as a spare.

Changing the Raw Water Pump Impeller

Close the raw water intake valve. Remove the pump cover and, using an impeller puller, screw drivers, or pliers, carefully pry the impeller out of the pump. Install the new impeller and gasket. Move the blades to conform to the curved cam plate and push the impeller into the pumps housing. When assembling, apply a thin coating of lubricant to the impeller and gasket. Open the raw water intake valve.

CAUTION: If any of the vanes have broken off the impeller, they must be found to prevent blockage in the cooling circuit. They often can be found in the heat exchanger.

INSPECTION: CHECK THE BASE OF EACH BLADE BY BENDING VIGOROUSLY. REPLACE THE IMPELLER IF THERE ARE ANY CRACKS.

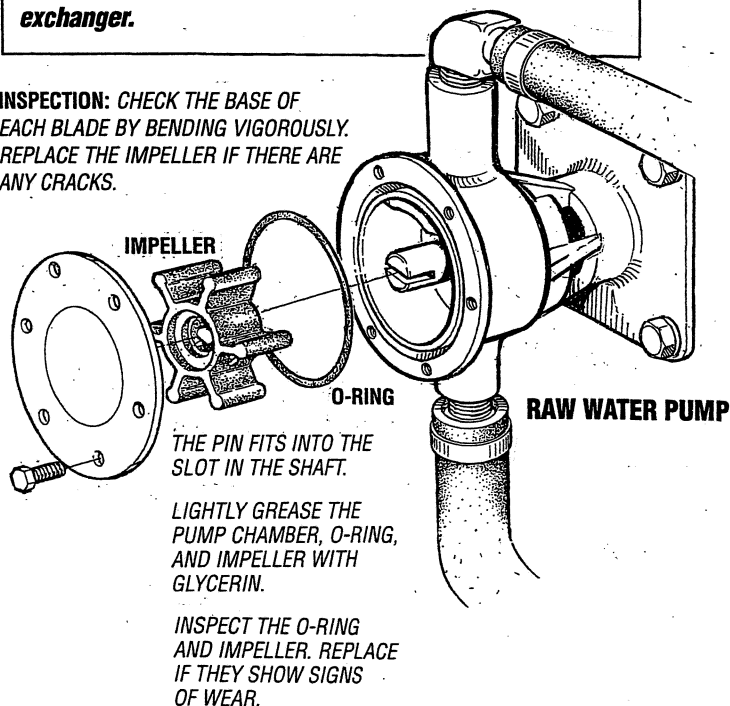

ENGINE LUBRICATING OIL

ENGINE OIL CHANGE

1. **Draining the Oil Sump.** Discharge the used oil through the sump drain hose (attached to the front of the engine) while the engine is warm. Drain the used oil completely, replace the hose in its bracket, and replace the end cap securely.

NOTE: Thread size for the lube oil drain hose capped end is 1/4 NPT.

Always observe the used oil as it is removed. A yellow/gray emulsion indicates the presence of water in the oil. Although this condition is rare, it does require prompt attention to prevent serious damage. Call a qualified mechanic should water be present in the oil. Raw water present in the oil can be the result of a fault in the exhaust system attached to the engine and/or a siphoning of raw water through the raw water cooling circuit into the exhaust, filling the engine. This problem is often caused by the absence of an anti-siphon valve, its poor location of or lack of maintenance.

2. **Replacing the Oil Filter.** When removing the used oil filter, you may find it helpful and cleaner to punch a hole in the upper and lower portion of the old filter to drain the oil from it into a container before removing it. This helps to lessen spillage. A small automotive filter wrench should be helpful in removing the old oil filter.

NOTE: Do not punch this hole without first loosening the filter to make certain it can be removed!

Place some paper towels and a plastic bag around the filter when unscrewing it to catch any oil left in the filter. (Oil or any other fluid on the engine reduces the engine's cooling ability. Keep your engine clean.) Inspect the old oil filter as it is removed to make sure that the rubber sealing gasket came off with the old oil filter. If this rubber sealing gasket remains sealed against the filter bracket, gently remove it.

When installing the new oil filter element, wipe the filter gasket's sealing surface on the bracket free of oil and apply a thin coat of clean engine oil to the rubber gasket on the new oil filter. Screw the filter onto the threaded oil filter nipple on the oil filter bracket, and then tighten the filter firmly by hand.

WARNING: Used engine oil contains harmful contaminants. Avoid prolonged skin contact. Clean skin and nails thoroughly using soap and water. Launder or discard clothing or rags containing used oil. Discard used oil properly.

NOTE: Generic filters are not recommended, as the material standards or diameters of important items on generic parts might be entirely different from genuine parts. Immediately after an oil filter change and oil fill, run the engine to make sure the oil pressure is normal and that there are no oil leaks around the new oil filter.

3. **Filling the Oil Sump.** Add new oil through the oil filler cap on the top of the engine or through the side oil fill. After refilling, run the engine for a few moments while checking the oil pressure. Make sure there is no leakage around the new oil filter or from the oil drain system, and stop the engine. Then check the quantity of oil with the lube oil dipstick. Fill to, but not over the high mark on the dipstick, should the engine require additional oil.

LUBRICATION DIAGRAM

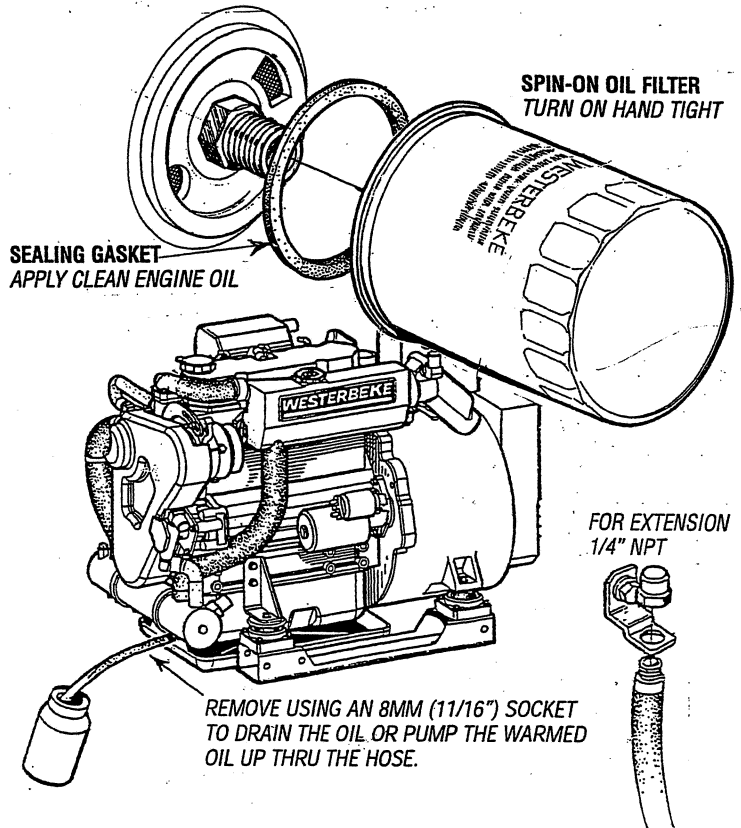
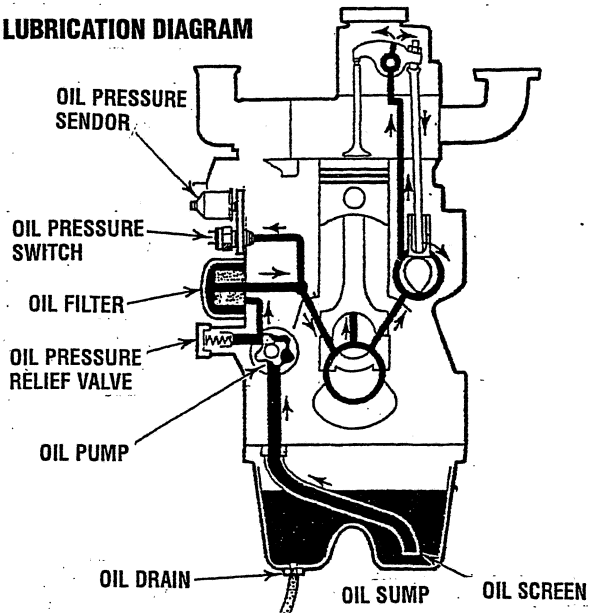

STARTER MOTOR

DESCRIPTION

The starting system includes the battery, starter motor, solenoid, and the start toggle switch.

When the start switch on the instrument panel is depressed, current flows and energizes the starter's solenoid coil. The energized coil becomes an electromagnet, which pulls the plunger into the coil, and closes a set of contacts, which allow high current to reach the starter motor. At the same time, the plunger also serves to push that starter pinion to mesh with the teeth on the flywheel.

To prevent damage to the starter motor when the engine starts, the pinion gear incorporates an over-running (one-way) clutch which is splined to the starter armature shaft. The rotation of the running engine may speed the rotation of the pinion but not the starter motor itself.

Once the start switch is released, the current flow ceases, stopping the activation of the solenoid. The plunger is pulled out of contact with the battery-to-start cables by a coil spring, and the flow of electricity is interrupted to the starter. This weakens the magnetic fields and the starter ceases its rotation. As the solenoid plunger is released, its movement also pulls the starter drive gear from its engagement with the engine fly-wheel.

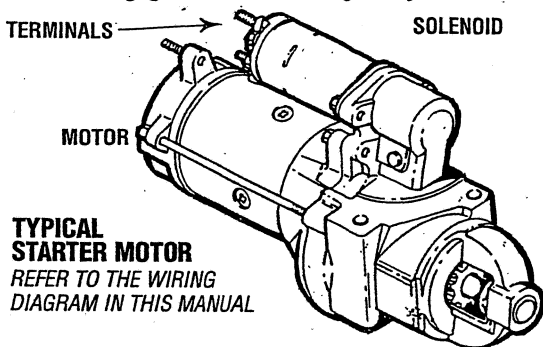

TROUBLESHOOTING

Prior to testing, make certain the batteries are at a full charge and that the starting system wiring connections (terminals) are clean and tight. Pay particular attention to the ground wire connections on the engine block.

To check the wiring, try cranking the starter for a few seconds, never more than 10 seconds at a time, then run your hand along the wires and terminals looking for warm spots that indicate resistance. Repair or replace any trouble spots.

Using a multimeter, test the voltage between the positive terminal stud on the start solenoid and the engine block (ground).

If you read 12 volts, the starter is faulty.

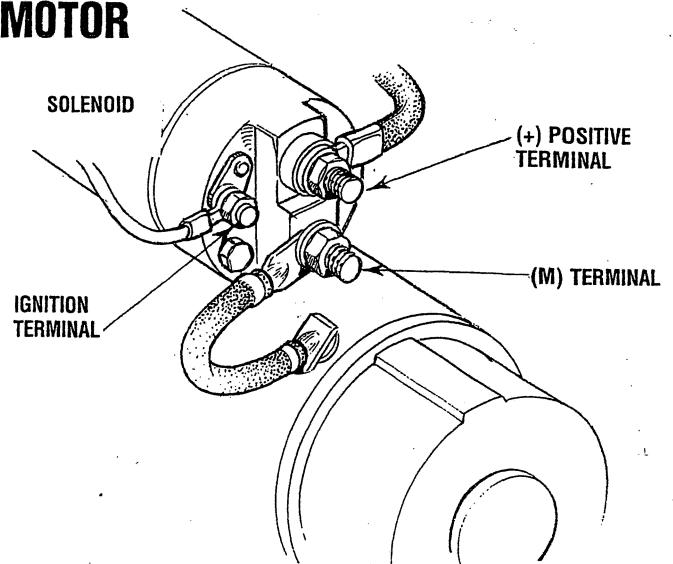

To test the ignition circuit, locate the ignition(s) terminal (it is one of the small terminal studs and is wired to the ignition circuit). Use a screwdriver, don't touch the blade, to jump from that ignition terminal to the positive battery connection terminal on the solenoid.

If the starter cranks, the fault lies with the ignition circuit.

If the solenoid clicks but nothing else happens, the starter motor is probably faulty.

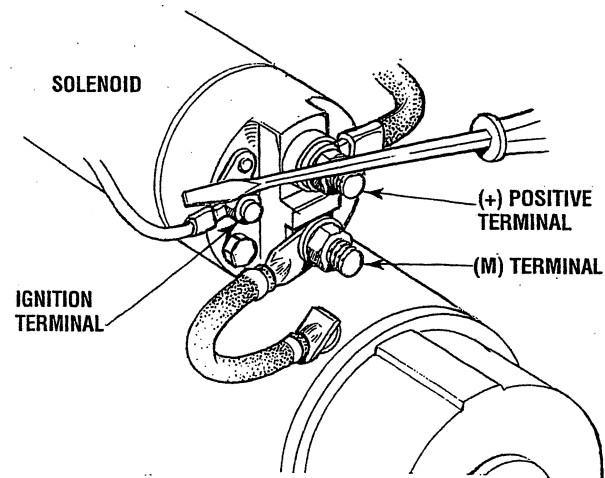

If nothing at all happens the solenoid isn't getting current. Check the battery isolation switch and inspect the wiring connections. It is also possible that the solenoid is defective.

WARNING: There will be arcing and sparks will fly when jumping terminals. Be certain the engine space is free of potentially explosive fumes, especially gasoline.

STARTER MOTOR

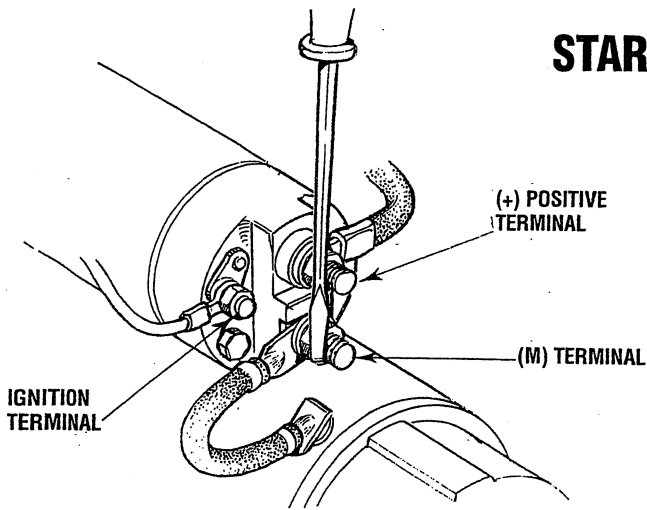

Test again by jumping the two large terminal studs. Hold the screwdriver blade firmly between the studs. Do not allow the screwdriver blade to touch the solenoid or starter casing, this would cause a short.

⚠ WARNING: *There will be arching as the full starting current should be flowing thru the blade of the screwdriver.*

If the starter spins, the solenoid is faulty.

If the starter fails to spin, the motor is probably faulty.

If no arching occurred. There is no juice reaching the solenoid.

NOTE: *Starter motors are either inertia type or pre-engaged. In the pre-engaged model, the solenoid also moves an arm that engages the starter motor to the flywheel of the engine. Using a screwdriver to bypass the solenoid on such a starter will run the motor without engaging the flywheel. Turn the starter switch on to provide the power to the solenoid. Hopefully it will create enough magnetic field for the arm to move even though the contacts inside the solenoid are bad.*

SERVICE

Westerbeke uses a standard marine starter motor which can be serviced or rebuilt at any starter motor automotive service center.

If replacing the starter motor, make certain the new motor is certified for marine use. Automotive starters do not meet USCG standards. If in doubt, contact your WESTERBEKE dealer.

TO REMOVE FOR SERVICE

1. Disconnect the negative battery cable.
2. If necessary, remove any components to gain full access to the starter motor.
3. Label and disconnect the wiring from the starter. (Do not allow wires to touch, tape over the terminals).
4. Remove the starter mounting bolts.
5. Remove the starter from the engine. In some cases the starter will have to be turned to a different angle to clear obstructions.

ENGINE ADJUSTMENTS

NOTE: WESTERBEKE recommends that the following engine adjustments be performed by a competent engine mechanic. The information below is provided to assist the mechanic.

DRIVE BELT ADJUSTMENT

For your safety, WESTERBEKE generator models come equipped with belt guards that cover over the belt(s) on the front of the engine. ("Out of sight - out of mind." The belt guard is NOT installed for that purpose.) Operators are advised that proper inspection, service, and maintenance is required.

Excessive drive belt tension can cause rapid wear of the belt and reduce the service life of the fresh water pump's bearing. A slack belt or the presence of oil on the belt can cause belt slipping, resulting in high operating temperatures.

The drive belt is properly adjusted if the belt can be deflected no less than 3/8 inch (10mm) and no more than 1/2 inch (12mm) as the belt is depressed with the thumb at the midpoint between the two pulleys on the longest span of the belt. A spare belt or belts should always be carried on board.

WARNING: Never attempt to check or adjust the drive belt's tension while the engine is in operation.

Adjusting Belt Tension

1. Remove the belt guard.
2. Loosen the adjusting strap bolt and the alternator pivot bolt.
3. With the belt loose, inspect for wear, cracks and frayed edges.
4. Pivot the alternator to properly tension the drive belt.
5. Tighten the adjusting strap bolt and the pivot bolt.
6. Replace the guard. Operate the generator for about 5 minutes and then shut the generator down.
7. Remove the guard and recheck the belt tension.
8. Replace the guard.

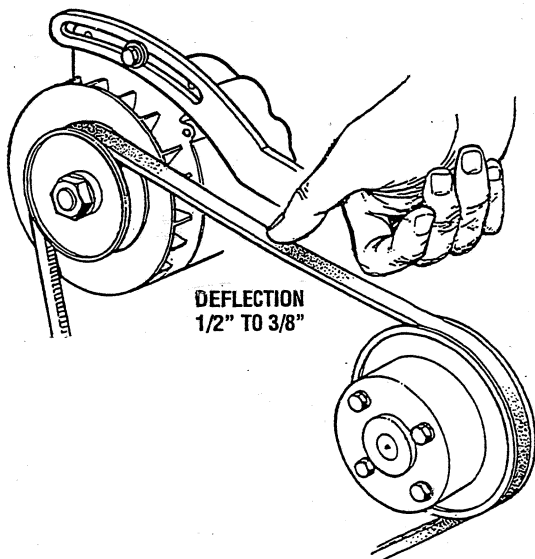

TORQUING THE CYLINDER HEAD BOLTS

After the initial break-in period (approximately 50 hours) and every 500 hours thereafter, the cylinder head bolts should be re-torqued.

Tighten the cylinder head bolts according to the sequence shown. Make sure the engine is cold when this is done. Before applying the specified torque to the bolt, loosen it 1/4 to 1/2 of a turn and then apply the torque. Follow this procedure according to the numbered sequence shown in the illustration to the right.

Bolts #1, 2 and 3, (12mm socket) 14 – 22 ft-lb

Bolts #4, 5, 6, 7, 8, 9, 10 and 11 (14mm socket) (54 – 61 ft-lb)

Rocketshaft Hold Down Bolts – 12mm socket (11 – 16 ft-lb)

Rocker Cover Hold Down Cap Nuts – (10mm socket) (snug)

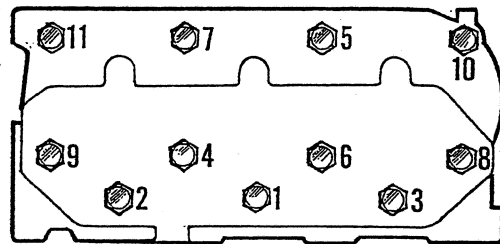

CYLINDER HEAD BOLT PATTERN

FUEL INJECTORS

In case of severe vibrations and detonation noise, have the injectors checked and overhauled by an authorized fuel injection service center. Poor fuel quality, contaminant's and loss of positive fuel pressure to the injection pump can result in injector faults. Since fuel injectors must be serviced in a clean room environment, it is best to carry at least one extra injector as a spare should a problem occur.

Before removing the old injector, clean the area around the base of the injector to help prevent any rust or debris from falling down into the injector hole. If the injector will not lift out easily and is held in by carbon build-up or the like, work the injector side-to-side with the aid of the socket wrench to free it, and then lift it out.

The injector seats in the cylinder head on a copper sealing washer. This washer should be removed with the injector and replaced with a new washer when the new injector is installed.

INJECTOR TO CYLINDER HEAD TIGHTENING TORQUE

40 ± 4 ft-lb (5.5 ± 0.5 kgf-m)

ENGINE ADJUSTMENTS

VALVE CLEARANCE ADJUSTMENT

NOTE: Retorque the cylinder head bolts before adjusting the engine's valves. See TORQUING THE CYLINDER HEAD BOLTS.

WARNING: Adjust the valve clearance when the engine is cold. Valves are adjusted by cylinder in the firing order of the engine. Tighten the cylinder head bolts to the specified torque before adjusting the valves.

Pull off the air breather pipe from the rocker cover, and take off the rocker cover bolts and the rocker cover to expose the rocker shaft and valve assembly.

Remove the glow plugs from each of the cylinders to enable the engine to be easily rotated by hand to position each cylinder for valve adjustment.

Valves are adjusted with the piston in the cylinder being adjusted is at TDC (top dead center) of its compression stroke. Each cylinder is adjusted following the engine's firing order (1-3-2 for WESTERBEKE's three cylinder engines).

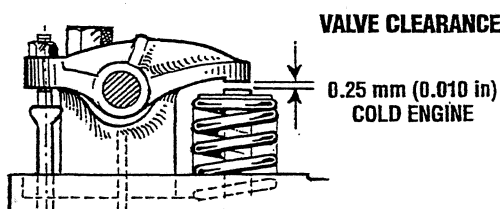

Valve adjustment beginning with cylinder #1. Rotate the crankshaft slowly and observe the operation of the valves for cylinder #1. Watch for the intake valve to open indicating the piston is on its intake stroke (the piston is moving down in the cylinder). Continue to rotate the crankshaft slowly and look for the intake valve to close. This indicates the piston is now starting its compression stroke (the piston is moving up in the cylinder towards TDC).

Align the TDC mark on the crankshaft front pulley with the timing marker on the front gear case cover when positioning the #1 Piston at TDC of its compression stroke. Confirm this by rotating the crankshaft approximately 20 degrees before and after this point and the two valves for the #1 cylinder should not move.

Adjust the valves in #1 cylinder for both intake and exhaust. Proceed to the next cylinder in the firing order.

Rotate the crankshaft 240 degrees in normal direction of rotation and adjust the next cylinder's valves in the firing order. Rotate the crankshaft another 240 degrees and adjust the next cylinders valves in the firing order.

Adjust each valve's clearance by inserting a 0.010 inch (0.25mm) feeler gauge between the rocker arm and the valve stem. Make sure to adjust all valves while the engine is cold.

Re-install the glow plugs (use anti-seize compound on the threads) and assemble the rocker cover and rocker cover belts. See the TIGHTENING TORQUE SCHEDULE in this manual.

ENGINE ADJUSTMENTS

NOTE: WESTERBEKE recommends that the following engine adjustments be performed by a competent engine mechanic. The information below is provided to assist the mechanic.

Injection Pump Timing Adjustment (Spill Timing)

If your engine's fuel injection timing is not properly adjusted, the engine will not operate properly, and may be difficult to start. Have the injection pump delivery rate checked by a well-established fuel injection shop. Adjust the injection as follows:

NOTE: The injection pump fuel rack needs to be in the full fuel delivery position when performing this spill timing. To do this, unscrew the fuel shut off solenoid and remove the side cover to expose the injection pump fuel rack. Manually move the fuel rack to the full fuel delivery position (move fully to the left) secure it in this position then proceed.

1. Remove the high pressure fuel line from between the No. 1 injector and the No. 1 fuel delivery valve holder.
2. Remove the No. 1 fuel delivery valve holder over "O" ring and remove the delivery valve spring beneath the holder.
3. Reinstall only the delivery valve holder and reattach the high pressure fuel line to the delivery holder. Attach it so that the end that would connect to the fuel injector is pointing away from the engine fuel will flow from this line during the timing check.

Rotate the engine's crankshaft in its normal direction of rotation to position piston No. 1 at the beginning of its compression stroke.

Move the throttle lever to its full open position and operation the electric lift pump. Slowly rotate the crankshaft clockwise (as viewed from the front), catching the fuel from the No. 1 fuel line, until the instant the fuel completely stops flowing (no drips). At this instant, the 15° BTDC timing mark on the crankshaft pulley should be directly aligned with the timing indicator on the front of the gear case ± .5 degrees.

If the specified injection timing (15° BTDC) cannot be attained, adjust the timing by increasing or decreasing the thickness of shim material under the injection pump's mounting flange to change the injection timing point. Changing the shim thickness by 0.004 inch (0.01mm) changes the injection timing by approximately one degree. To advance the timing, decrease the shim thickness, as required. To retard the timing, increase the shim thickness, as required. Refer to your Generator's Parts List for shim part numbers.

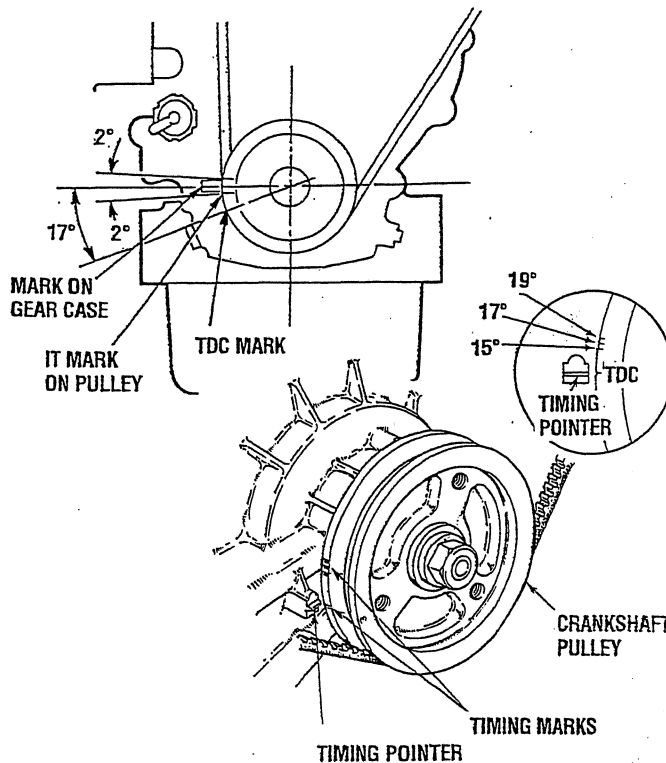
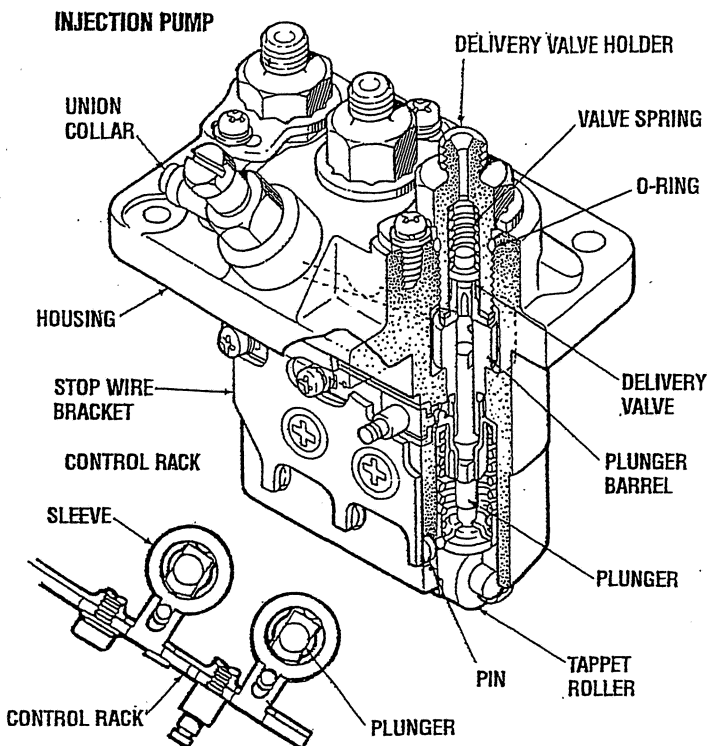

ENGINE ADJUSTMENTS

GLOW PLUGS

The glow plugs are wired through the preheat solenoid. When PREHEAT is pressed at the control panel this solenoid should "click" on and the glow plug should begin to get hot.

INSPECTION

To inspect the plug, remove the electrical terminal connections, then unscrew or unclamp each plug from the cylinder head. Thoroughly clean each plug's tip and threads with a soft brush and cleaning solution to remove all the carbon and oil deposits. While cleaning, examine the tip for wear and burn erosion; if it has eroded too much, replace the plug.

TESTING

An accurate way to test glow plugs is with an ohmmeter. Touch one prod to the glow plug's wire connection, and the other to the body of the glow plug, as shown. A good glow plug will have a 1.0 - 1.5 ohm resistance. This method can be used with the plug in or out of the engine. You can also use a multimeter to test the power drain (8 - 9 amps per plug).

⚠ WARNING: These glow plugs will become very hot to the touch. Be careful not to burn your fingers when testing the plugs.

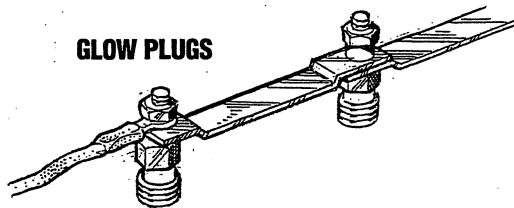

Re-install the plugs in the engine and test them again. The plugs should get very hot (at the terminal end) within 7 to 15 seconds. If the plugs don't heat up quickly, check for a short circuit. When reinstalling the glow plugs, use anti-seize compound on the threads.

⚠ WARNING: Do not keep a glow plug on for more than 30 seconds.

GLOW PLUG TIGHTENING TORQUE
1.0 - 1.5 M-KG (7 - 11 FT-LB)

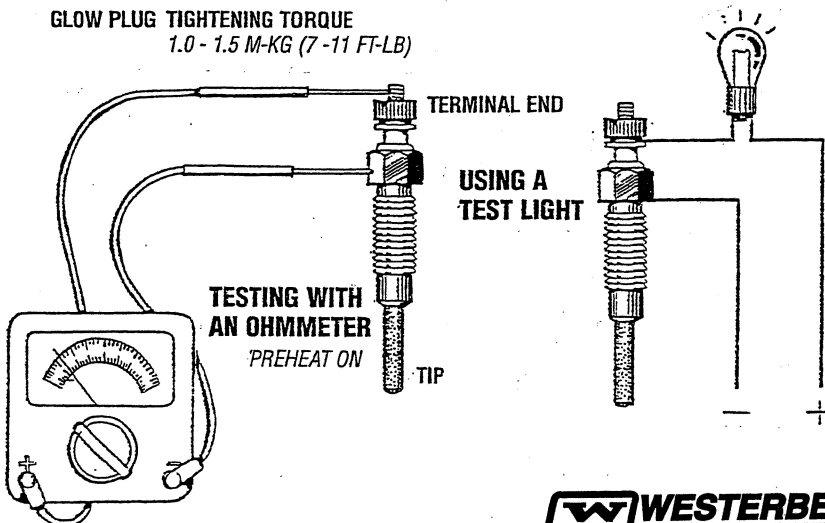

OIL PRESSURE

To test the oil pressure, remove the oil pressure sender, then install a mechanical oil pressure gauge in its place. After warming up the engine, set the engine speed at 1800 rpm and read the oil pressure gauge.

Oil Pressure 35 - 55 lb/in² (2.5 - 3.8 kg/cm²)

LOW OIL PRESSURE

A gradual loss of oil pressure usually indicates a worn bearing. A rapid loss of oil pressure indicates a specific bearing failure. For additional information on low oil pressure readings, see the *ENGINE TROUBLESHOOTING* chart.

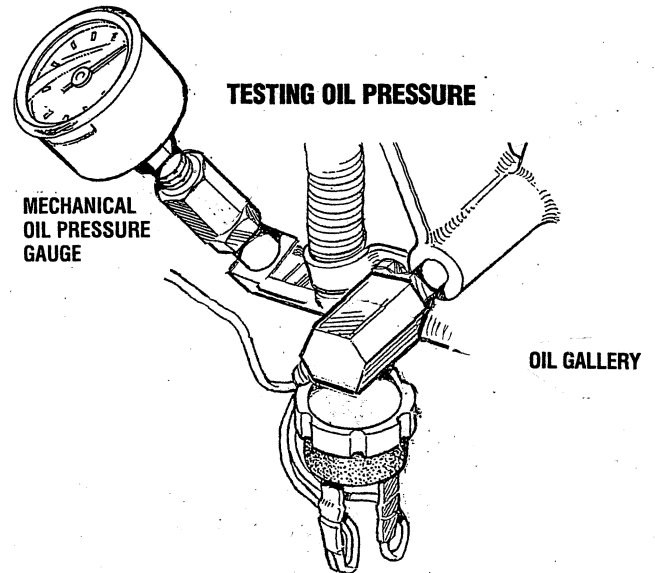

OIL PRESSURE SWITCH

The oil pressure safety shut-down switch is located at the front of the engine. Adjacent to the switch is an access port 1/8npt that will allow for the connecting of a mechanical oil pressure gauge when checking for proper oil pressure during engine operation.

ENGINE TROUBLESHOOTING

ENGINE SHUTDOWN/CHECK ENGINE LIGHT

ELECTRONIC CONTROLLER

The Electronic Control Unit (ECU) monitors and controls all aspects of the drive engines operation. The unit is factory programmed and the programming can not be altered. The ECU is mounted on the engine block just adjacent to the fuel injection pump and controls the injection pumps operation. If an operating fault occurs, The ECU will shutdown the engine and illuminate the **Check Engine LED**. When the operating fault has been investigated and corrected, The ECU must be re-set to re-start the engine. To re-set the ECU, turn the DC breaker on the control panel OFF, then ON.

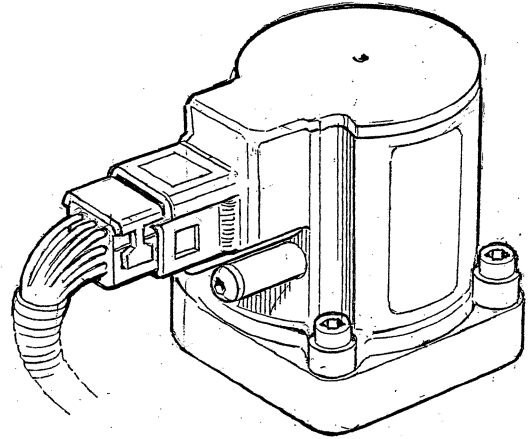

ENGINE SHUTDOWN CHECK ENGINE/LED IS ILLUMINATED

PROBLEM	PROBABLE CAUSE	VERIFICATION/REMEDY
LOW OIL PRESSURE	<ol style="list-style-type: none"> 1. Oil level low/oil leak. 2. Lack of oil pressure. 3. AGround connection. 4. Faulty oil pressure switch. 5. Faulty control module. 	<ol style="list-style-type: none"> 1. Check oil level, add oil and repair leaks. 2. Test oil pressure. If OK, test oil pressure sensor, inspect oil filter, inspect oil pump. 3. Check ground connection. 4. Check sensor/replace. 5. Inspect all the plug in connections/replace ECU.
HIGH COOLANT TEMPERATURE	<ol style="list-style-type: none"> 1. Check system coolant level. 2. Sea water pump. 3. Check water pump drive belt. 4. Faulty temperature switch. 5. Ground connection. 6. Faulty control module (ECU). 	<ol style="list-style-type: none"> 1. Add coolant. Check for leaks. 2. Inspect impeller/pump/replace. 3. Adjust belt tension, replace belt. 4. Check sensor/replace. 5. Check ground circuit. 6. Check plug connections/replace ECU.
BATTERY VOLTAGE (HIGH DC/LOW DC)	<ol style="list-style-type: none"> 1. Check alternator drive belt.. 2. Check charge voltage. 3. Check battery connections. 4. faulty battery. 	<ol style="list-style-type: none"> 1. Adjust tension/replace if worn. 2. Check excitation. Replace/repair alternator. 3. Check + and - cables from battery to engine. 4. Load test battery.
GENERATOR FREQUENCY Overspeed Underspeed	<ol style="list-style-type: none"> 1. Check engine speed. 2. Check fuel supply. 3. Amperage load. 4. Crank cycle with no start. (underspeed fault) 5. Generator Shut-down. (underspeed fault) 	<ol style="list-style-type: none"> 1. Check speed setting. 2. Inspect filters/replace filters. Test fuel pump operation. 3. Check + and - cables from battery to engine. 4. Check cause for no start. 5. Check MPU (voltage cranking. (Check MPU - coil resistance)
HIGH EXHAUST (External Fault) No shutdown No LED Software needed to diagnosis	<ol style="list-style-type: none"> 1. Check sea water flow. 2. Faulty exhaust temperature switch. 3. Ground connection. 4. Sea water pump. 5. Faulty fire suppression system. 	<ol style="list-style-type: none"> 1. Inspect thru hull fitting, hose and strainer. Correct as needed. 2. Test/replace. 3. Check ground circuit. 4. Inspect impeller/replace. 5. By-pass system/check.

Note: Refer to the Table of Contents for additional TROUBLESHOOTING pages in this manual.

ENGINE TROUBLESHOOTING

The following troubleshooting chart describes certain problems relating to engine service, the probable causes of these problems, and the recommendations to overcome these problems. If the engine shuts down (**Check Engine/LED is illuminated**), refer to ECU Troubleshooting Chart in this manual.

NOTE: The engine's electrical system is protected by a 20-ampere manual reset circuit breaker. The preheat solenoid is mounted on the same bracket.

PROBLEM	PROBABLE CAUSE	VERIFICATION/REMEDY
Engine can not be stopped.	1. Faulty DC alternator.	1. Remove Exc/R connection off alternator. Repair alternator.
Starting battery not being.	1. DC charge circuit faulty. 2. Alternator drive.	1. Perform DC voltage check of charge circuit. See DC alternator section in this manual. 2. Check drive belt tension, loose connections, voltage output, excitation voltage present at Exo/R terminal.
Engine slows and stops.	1. Fuel starvation. 2. Contaminated fuel. 3. Exhaust restriction.	1. Check fuel supply, filters, tank vent. 2. Check filters for contaminates/water. 3. Check for blockage, collapsed exhaust hose, carbon build up in water injected exhaust elbow.
Engine overheats and shuts down.	1. Antifreeze coolant not circulating.	1. Loss of coolant. Check system for leak. 2. Air in system. Expel air. Add coolant as needed. Check recovery circuit. 3. Thermostat stuck closed. Check/test/replace.
Preheat switch depressed No panel indications or electrical fuel pump.	1. Battery switch off. 2. 20 Amp breaker tripped. 3. Emergency stop switch open. 4. 7.5 amp fuse faulty. 5. Blocking diode open. 6. K2 Relay faulty.	1. Check switch. 2. Check/re-set 20 amp breaker. 3. Check/close switch. 4. Check/test fuse. 5. Test diode. 6. Check/test K2 Relay.
Start switch depressed No starter activation.	1. K1 Relay faulty. 2. Faulty starter solenoid. 3. Low DC battery charge. 4. Poor/loose battery cable connection.	1. Check/test K1 Relay. 2. Test solenoid. 3. Check battery charge state. 4. Check connections.

TROUBLESHOOTING WATER TEMPERATURE AND OIL PRESSURE GAUGES

If the gauge reading is other than what is normally indicated by the gauge when the instrument panel is energized, the first step is to check for 12 volts DC between the ignition (B+) and the Negative (B-) terminals of the gauge.

Assuming that there is 12 volts as required, leave the instrument panel energized and perform the following steps:

1. Disconnect the sender wire at the gauge and see if the gauge reads zero, which is the normal reading for this situation.
2. Remove the wire attached to the sender on the engine and ground it to the engine. The gauge in the panel should register full scale, which is normal for this situation. DC voltage at the oil and temperature sender to ground when the engine is first started will be high (10 - 11VDC) and will fall as the oil pressure rises and coolant rises. This DC voltage will generally stabilize in the 5 - 7VDC range depending on what your engines normal oil pressure and coolant temperature are.

If both of the above gauge tests are positive, the gauge is undoubtedly OK and the problem lies either with the conductor from the sender to the gauge or with the sender. If either of the above gauge tests are negative, the gauge is probably defective and should be replaced.

Assuming the gauge is OK, check the conductor from the sender to the sender terminal at the gauge for continuity.

Check that the engine block is connected to the ground. Some starters have isolated ground terminals and if the battery is connected to the starter (both plus and minus terminals), the ground side will not necessarily be connected to the block.

ENGINE TROUBLESHOOTING

PROBLEM	PROBABLE CAUSE	VERIFICATION/REMEDY
Generator engine cranks but does not start.	<ol style="list-style-type: none"> 1. Faulty preheat circuit. 2. Faulty fuel pump. 3. Fuel supply. 4. Fuel filter(s) contaminated. 	<ol style="list-style-type: none"> 1. Test/check circuit components. 2. Test fuel pump operation. 3. Check fuel ON. 4. Inspect all filters.
Starting battery looses charge.	<ol style="list-style-type: none"> 1. Faulty battery. 2. Oil pressure switch stuck, closed contacts. 3. DC alternator faults. 	<ol style="list-style-type: none"> 1. Load test battery. 2. Panel/fuel pump activated after shutdown. 3. Check alternator charge rate.
Engine shuts down. Low oil pressure.	<ol style="list-style-type: none"> 1. Loss of oil. 2. Oil pressure switch. 3. Contaminated oil. 	<ol style="list-style-type: none"> 1. Locate leak and correct. 2. Test/replace. 3. Change oil, locate source of contaminates.
Smokey exhaust.	<ol style="list-style-type: none"> 1. Blue smoke. 2. White smoke. 3. Black smoke. 	<ol style="list-style-type: none"> 1. Crankcase overfilled. 2. Incorrect grade of oil. 1. Engine running cold, thermostat stuck open. 2. Faulty injector. 1. Lack of air, check intake/air filter. 2. Incorrect fuel grade. 3. Valves need adjustment. 4. Low compression.
Engine starts, runs then shutdown. (stays running with Preheat depressed).	<ol style="list-style-type: none"> 1. Safety shutdown switch faulty. 	<ol style="list-style-type: none"> 1. Check safety shutdown switch (oil, coolant, exhaust)
Engine has loss of horsepower.	<ol style="list-style-type: none"> 1. MAP sensor (manifold absolute pressure). 	<ol style="list-style-type: none"> 1. Test/replace.

ALTERNATOR TESTING

DESCRIPTION

The charging system consists of an alternator with a voltage regulator, an engine DC wiring harness, a mounted DC circuit breaker and a battery with connecting cables. Because of the use of integrated circuits (IC's) the electronic voltage regulator is very compact and is mounted internally or on the back of the alternator.

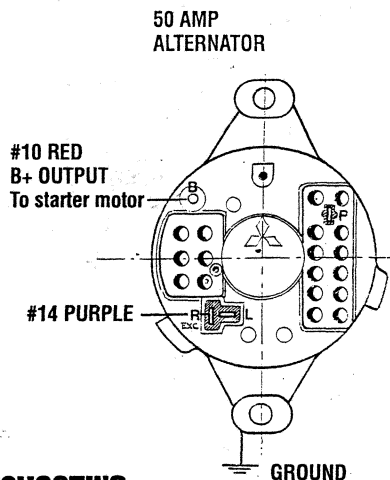

TROUBLESHOOTING

WARNING: A failed alternator can become very hot. Do not touch until the alternator has cooled down.

This troubleshooting section is to determine if a problem exists with the charging circuit or with the alternator. If it is determined that the alternator or voltage regulator is bad, it is best to have a qualified technician check it out.

The alternator charging circuit charges the starting battery and the service battery. An isolator with a diode, a solenoid, or a battery selector switch is usually mounted in the circuit to isolate the batteries so the service battery is not discharged along with the service battery. If the alternator is charging the starting battery but not the service battery, the problem is in the service battery charging circuit and not with the alternator.

WARNING: Before starting the engine make certain that everyone is clear of moving parts! Keep away from sheaves and belts during test procedures.

WARNING: Multimeters and DC Circuits: DC and AC circuits are often mixed together in marine applications. Always disconnect shore power cords, isolate DC and AC converters and shut down generators before performing DC testing. No AC tests should be made without proper knowledge of AC circuits.

Testing the Alternator

1. Start the Engine.
2. After a few minutes of running measure the starting battery voltage at the battery terminals using a multi-meter set on DC volts. The voltage should be increasing toward 14 volts. If it is, the alternator is working. Turn to Step 4.

TESTING THE STARTING BATTERY - ALTERNATOR (ENGINE RUNNING)

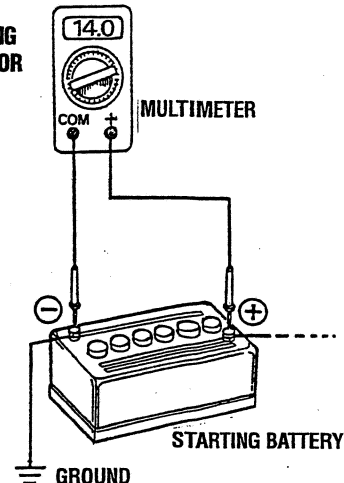

3. If the starting battery voltage remains around 12 volts after the engine is started and run for a few minutes, a problem exists with the alternator or the charging circuit.
 - a. Turn off the engine. Inspect all wiring and connections. Ensure that the battery terminals and the engine ground connections are tight and clean.

CAUTION: To avoid damage to the battery charging circuit, never shut off the engine battery switch when the engine is running!

- b. If a battery selector switch is in the charging circuit, ensure that it is on the correct setting.
- c. Turn on the ignition switch, but do not start the engine.
- d. Check the battery voltage. If your battery is in good condition the reading should be 12 to 13 volts.

TESTING THE STARTING BATTERY - ENGINE OFF

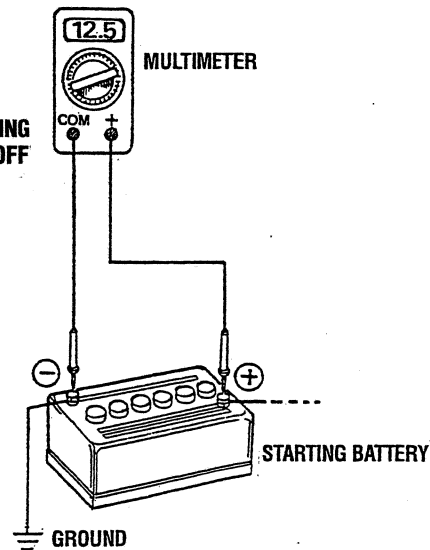

ALTERNATOR TESTING

- e. Now check the voltage between the alternator output terminal (B+) and ground. If the circuit is good, the voltage at the alternator should be the same as the battery, or if an isolator is in the circuit the alternator voltage will be zero. If not, a problem exists in the circuit between the alternator and the battery. Check all the connections - look for an opening in the charging circuit.

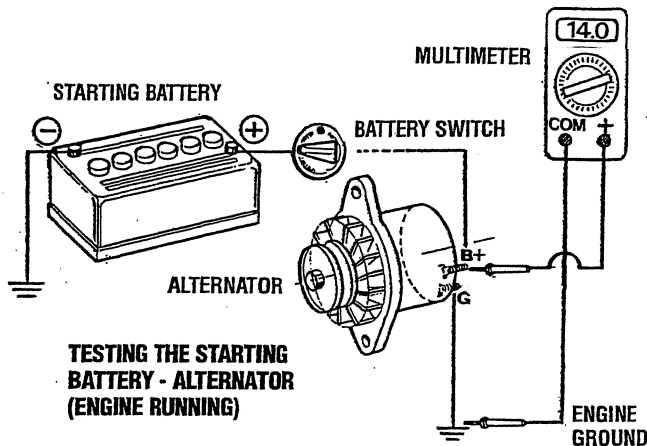

- f. Start the engine again. Check the voltage between the alternator output and ground.

The voltage reading for a properly operating alternator should be between 13.5 and 14.5 volts. If your alternator is over- or under-charging, have it repaired at a reliable service shop.

NOTE: Before removing the alternator for repair, use a voltmeter to ensure that 12 volts DC excitation is present at the EXC terminal if the previous test showed only battery voltage at the B output terminal. If 12 volts are not present at the EXC terminal, trace the wiring looking for breaks and poor connections.

Alternator is Working

4. Check the voltage of the service battery. This battery should have a voltage between 13 and 14 volts when the engine is running. If not, there is a problem in the service battery charging circuit. Troubleshoot the service battery charging circuit by checking the wiring and connections, the solenoid, isolator, battery switch and the battery itself.

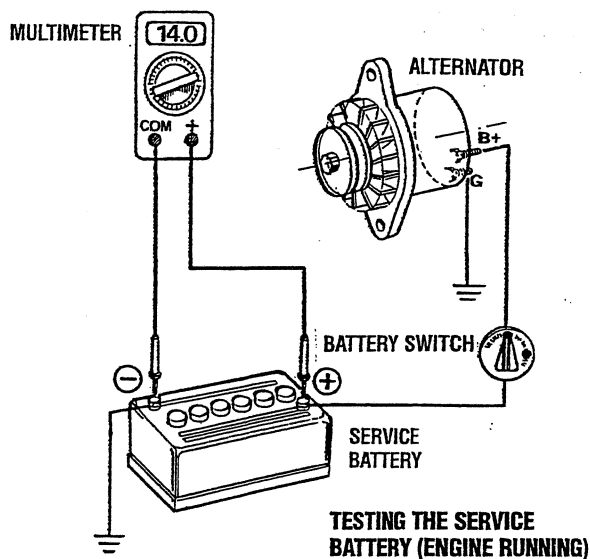

CAUTION: When performing tests on the alternator charging circuit do not use a high voltage tester (i.e. Megger). You can damage the alternator diodes.

ALTERNATOR INSPECTION

When rebuilding the engine. The alternator should be cleaned and inspected. The housing can be wiped off with a solvent and the alternator terminal studs should be cleaned with a wire brush. Make certain those studs are tight. Also clean the wiring connections that connect to the wiring harness.

Turn the rotor pulley by hand. It should turn smoothly.

Depending on when the alternator was last serviced, the brushes may need replacing. If the alternator is at all suspect, send it to a service shop for testing and overhaul.

DC CIRCUIT/BATTERY

BATTERY CHARGING

The DC Circuit functions to start, operate and stop the generator's engine. The circuit is best understood by reviewing the DC Wiring Diagram and Wiring Schematic. The engine's DC wiring is designed with three simple basic circuits: start, run and stop.

The engine has a 12 volt DC electrical control circuit that is shown on the Wiring Diagrams. Refer to these diagrams when troubleshooting or when servicing the DC electrical system or the engine.

CAUTION: *To avoid damage to the battery charging circuit, never shut off the engine battery switch while the engine is running. Shut off the engine battery switch, however, to avoid electrical shorts when working on the engine's electrical circuit.*

SPECIFICATIONS

The minimum recommended capacity of the battery used in the engine's 12-volt DC control circuit is 600-900 (CCA).

TESTING THE CIRCUIT

If the starting battery is not being charged. Verify Dc voltage output from the alternator's B+ output terminal. Check that there is excitation voltage at the alternator's "R" terminal. Check battery cable connections DC + and DC - both at the engine and at the starting battery.

BATTERY MAINTENANCE

Review the manufacturer's recommendations and then establish a systematic maintenance schedule for your engine's starting batteries and house batteries.

- Check the electrolyte level and specific gravity with a hydrometer.
- Use only distilled water to bring electrolytes to a proper level.
- Make certain that battery cable connections are clean and tight to the battery posts (and to your engine).
- Keep your batteries clean and free of corrosion.

WIRING DIAGRAM

056225

- NOTES:
- ECU PIN 8 CONTROLS ENGINE SPEED FOR AC LINE POWER FREQUENCY
60HZ PIN 8 CONNECTED TO TB1-6
50HZ PIN 8 CONNECTED TO TB1-8
 - FIRE SUPPRESSION SYSTEM CONNECTION.
REMOVE JUMPER
 - 56209 - HARNESS GENSET 5.5, 7.6 EG DSL
 - 56223 - HARNESS GEN PHL EG DSL
 - 56224 - HARNESS GEN PHL 5, 8-15 EG
 - 56240 - HARNESS INSTR PHL EG DSL
 - 56261 - HARNESS PHL BOX COHN EG DSL
 - 15223 - JUMPER, TERMINAL BLOCK 20 AMP

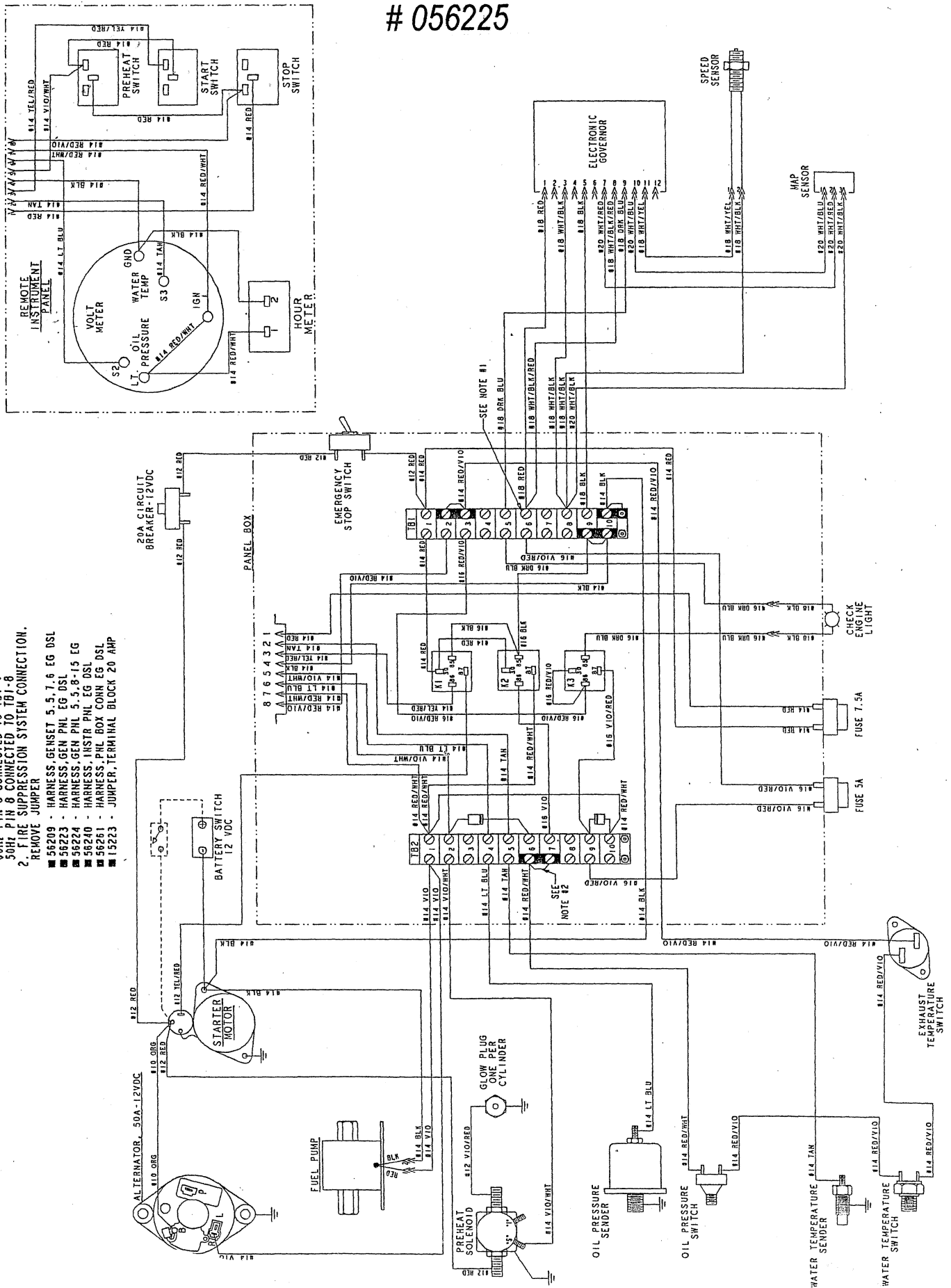

WIRING SCHEMATIC

#056225

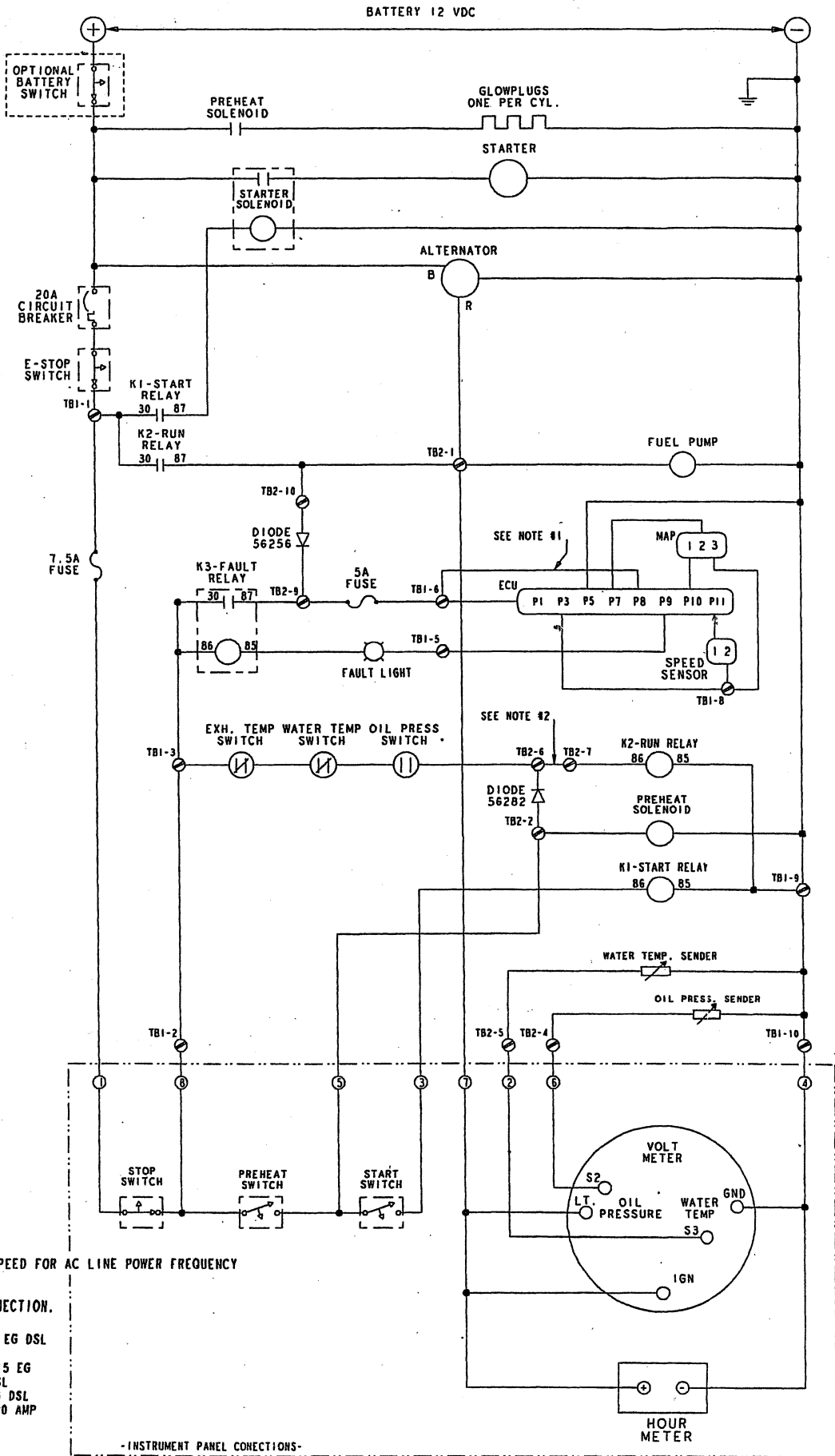

- NOTES:**
- ECU PIN 8 CONTROLS ENGINE SPEED FOR AC LINE POWER FREQUENCY
60Hz PIN 8 CONNECTED TO TBI-6
50Hz PIN 8 CONNECTED TO TBI-8
 - FIRE SUPPRESSION SYSTEM CONNECTION.
REMOVE JUMPER
- 58209 - HARNESS, GENSET 5.5, 7.6 EG DSL
 - 58223 - HARNESS, GEN PNL EG DSL
 - 58224 - HARNESS, GEN PNL 5.5, 8-15 EG
 - 58240 - HARNESS, INSTR PNL EG DSL
 - 58261 - HARNESS, PNL BOX CONN EG DSL
 - 15223 - JUMPER, TERMINAL BLOCK 20 AMP

- INSTRUMENT PANEL CONNECTIONS -

REMOTE START/STOP PANEL WIRING DIAGRAM #56321

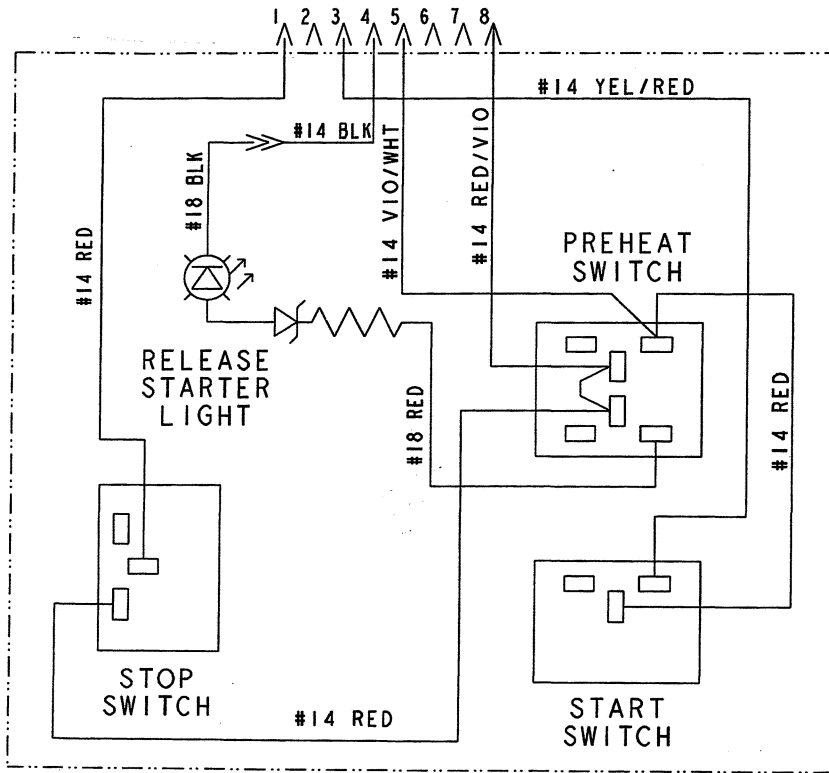

EXTENSION HARNESS
15FT, 8 PIN, PN#36236
30FT, 8 PIN, PN#36235

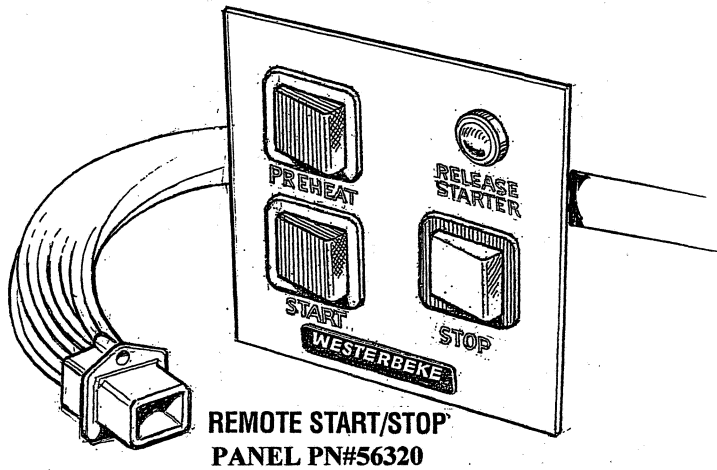

SPECIFICATIONS - 5.5/5.0KW EG GENERATOR

ENGINE SPECIFICATIONS

Engine Type	Diesel, four-cycle, three-cylinder, fresh water-cooled, vertical in-line overhead valve mechanism (9.2 Hp at 1800 rpm maximum)
Aspiration	Naturally aspirated
Governor	Centrifugal type
Combustion Chamber	Swirl type
Bore & Stroke 5.5 Kw	2.99 x 2.76 inches (76 x 70 mm)
Piston Displacement 5.5 Kw	58.00 cubic inches (0.952 liters)
Firing Order	1 - 3 - 2
Direction of Rotation	Clockwise, when viewed from the front
Maximum Torque	27 ft-lb (3.4 kg-m) at 1800 rpm
Compression Ratio	21:1
Dimensions	Height: 19.9 inches (505.5 mm) Width: 16.0 inches (406.4 mm) Length: 27.2 inches (690.9 mm)
Weight	336 lbs (152.4 kgs)
Fuel Consumption 5.5 Kw	0.54 US gph (2.01 lph) approximate
Inclination	Continuous 14° (BCDB: 14°) Temporary 25° (not to exceed 30 min.)

TUNE-UP SPECIFICATIONS

Compression Pressure	398 psi (28 kg/cm ²) at 280 rpm limit (Limit of Difference between cylinders) 47.2 psi (3.0 kg/cm ²)
Valve Timing	Intake Opens 19° BTDC Intake Closes 51° ABDC Exhaust Opens 51° BBDC Exhaust Closes 19° ATDC
Valve Seat Angle	Intake 45° Exhaust 45°
Engine Speed	1800 rpm 60 Hertz 1500 rpm 50 Hertz
Valve Clearance (Engine Cold)	Intake and Exhaust 0.098 inches (0.25 mm)
Injector Pressure	1968 ± 142 psi (140 ± 10 kg/cm ²)
Engine Timing (Spill) 5.5 Kw	15° BTDC ± .5

LUBRICATION SYSTEM

General	Pressure fed system by geared pump
Oil Filter	Full flow, paper element, spin-on type
Sump Capacity (not including filter)	3.2 U.S. qts (3.03 liters)
Operating Oil Pressure (engine hot)	35 - 55 psi (2.5 - 3.8 kg/cm ²)
Oil Grade	API Specification CF, CF-4, CG-4, CH-4, CI-4 or better. SAE 10W-40 or 15W-40

EXHAUST EMISSIONS SYSTEMS

Emission Control Systems	Smoke puffer limiter
--------------------------	----------------------

FUEL SYSTEM

General	Open flow, self bleeding - self priming
Fuel	No. 2 diesel oil (cetane rating of 45 or higher)
Fuel Injection Pump	In-line plunger (Bosch type)
Fuel Injection Timing (Spill timing)	15° ± 5° BTDC (Before Top Dead Center)
Nozzle	Throttle type
Fuel Filter	Cartridge type
Air cleaner	Plastic intake silencer - cleaner
Air Flow (Engine Combustion)	25.6 cfm (0.7 cmm) BCD, BCDA, BCDB 30.2 cfm (0.6 cmm) BCD 5.5 Kw

ELECTRICAL SYSTEM

Starting Battery	12-Volt, (-) negative ground
Battery Capacity	600 - 900 Cold Cranking Amps (CCA)
Starter	12-Volt, reduction
Starting Aid	Glow plugs, sheathed type
DC Cranking Amps	175 - 200 Amps (engine cold)
DC Charging	51 Amp IC 13-14 volts DC (in generator)
Voltage Regulator	Capacitor

COOLING SYSTEM

General	Fresh water-cooled block, thermostatically-controlled
Operating Temperature	170° - 190° F (77° - 88° C)
Fresh Water Pump	Centrifugal type, metal impeller, belt-driven
Raw Water Flow, at 3600 rpm	6.5 - 7.0 US gpm (24.6 - 22.5 lpm) (measured before discharging into exhaust elbow).
System Capacity (fresh water)	4.0 qts (3.79 liters)

AC GENERATOR (Single Phase)

Single Phase	Brushless, four-pole, revolving field. Self-exciting, capacitor saturated field excitation. Pre-lubricated, single-bearing design. 120 volts, single phase
Voltage - Single Phase	120 Volts - 60 Hertz 220 Volts - 50 Hertz.
Voltage Regulation:	±5% no load to full load.
Frequency Regulation:	.5 Hertz (6%) no load to full load.
Rating (Volts/Amps) 5.5 Kw	60 Hertz (1800 rpm) 120 Volts/45.8 Amps 50 Hertz (1500 rpm) 220 Volts/21.7 Amps
Generator Compartment Ambient Temperature Recommendations	120°F (50°C) maximum NOTE: Forced ventilation should be provided to maintain generator compartment temperatures below 120°F (50°C)
Electromagnetic Interference level	Exceeds requirements for most marine radio telephones and standard televisions. Meets CE (Certified Europe) requirements
Generator Cooling Air Requirements	175 - 200 cfm (4.95 - 5.66 cmm) (60 Hertz) at 1800 rpm

NOTE: Increase air supply 15% for 50 Hertz operation @1500 rpm

GENERATOR INFORMATION

USE OF ELECTRIC MOTORS

The power required to start an electric motor is considerably more than is required to keep it running after it is started. Some motors require much more current to start them than others. Split-phase (AC) motors require more current to start, under similar circumstances, than other types. They are commonly used on easy-starting loads, such as washing machines, or where loads are applied after the motor is started, such as small power tools. Because they require 5 to 7 times as much current to start as to run, their use should be avoided, whenever possible, if the electric motor is to be driven by a small generator. Capacitor and repulsion-induction motors require from 2 to 4 times as much current to start as to run. The current required to start any motor varies with the load connected to it. An electric motor connected to an air compressor, for example, will require more current than a motor to which no load is connected.

In general, the current required to start 115-Volt motors connected to medium starting loads will be approximately as follows:

MOTOR SIZE (HP)	AMPS FOR RUNNING (AMPERES)	AMPS FOR STARTING (AMPERES)
1/6	3.2	6.4 to 22.4*
1/4	4.6	9.2 to 32.2*
1/3	5.2	10.4 to 72.8*
1/2	7.2	14.4 to 29.2*
3/4	10.2	20.4 to 40.8*
1	13	26 to 52

***NOTE:** In the above table the maximum Amps for Starting is more for some small motors than for larger ones. The reason for this is that the hardest starting types (split-phase) are not made in larger sizes.

Because the heavy surge of current needed for starting motors is required for only an instant, the generator will not be damaged if it can bring the motor up to speed in a few seconds. If difficulty is experienced in starting motors, turn off all other electrical loads and, if possible, reduce the load on the electric motor.

Required Operating Speed

Run the generator first with no load applied, then at half the generator's capacity, and finally loaded to its full capacity as indicated on the generator's data plate. The output voltage should be checked periodically to ensure proper operation of the generating plant and the appliances it supplies. If an AC voltmeter or ampere meter is not installed to monitor voltage and load, check it with a portable meter and amp probe.

NOTE: When the vessel in which the generator is installed contains AC equipment of 120 volts only, it is recommended that the generator's AC terminal block be configured to provide one 120 volt AC hot leg for the vessel's distribution panel. This will ensure good motor starting response from the generator.

Generator Frequency Adjustment

Frequency is a direct result of engine/generator speed, as indicated by the following:

- When the generator is run at 1800 RPM, the AC voltage output frequency is 60 Hertz.
- When the generator is run at 1500 RPM, the AC voltage output frequency is 50 Hertz.

Therefore, to change the generator's frequency, the generator's drive engine's speed must be changed. A reconfiguration of the AC output connections at the generator is also necessary.

Generator Maintenance

- Maintaining reasonable cleanliness is important. Connections of terminal boards and rectifiers may become corroded, and insulation surfaces may start conducting if salts, dust, engine exhaust, carbon, etc. are allowed to build up. Clogged ventilation openings may cause excessive heating and reduced life of windings.
- For unusually severe conditions, thin rust-inhibiting petroleum-base coatings, should be sprayed or brushed over all surfaces to reduce rusting and corrosion. Typical materials suggested are Daubert Chemical Co. "Non-Rust AC-410" and Ashland "Tectyle 506" or equivalent.
- In addition to periodic cleaning, the generator should be inspected for (a) tightness of all connections, (b) evidence of overheated terminals and (c) loose or damaged wires.
- The drive discs on single bearing generators should be checked periodically if possible for tightness of screws and for any evidence of incipient cracking failure. Discs should not be allowed to become rusty because rust may accelerate cracking. The bolts which fasten the drive disc to the generator shaft must be hardened steel SAE grade 8, identified by 6 radial marks, one at each of the 6 corners of the head.
- The rear armature bearing is lubricated and sealed; no maintenance is required. However, if the bearing becomes noisy or rough-sounding, have it replaced.
- Examine bearing at periodic intervals. No side movement of shaft should be detected when force is applied. If side motion is detectable, bearings are wearing or wear on shaft of bearing socket outside bearing has occurred. Repair must be made quickly or major components will rub and cause major damage to generator.

The generator's data plate gives the voltage, current, and frequency rating of the generator. An AC wiring decal is on the inside of the louvered cover at the generator end that includes the AC voltage connections. These voltage diagrams are also shown on these pages.

BC GENERATOR SINGLE PHASE

NOTE: WESTERBEKE recommends that the following generator tests and adjustments be performed by a qualified technician.

DESCRIPTION

The BC generator is a brushless, self-excited generator which requires only the driving force of the engine to produce an AC output. The stator houses two sets of windings; the main stator windings and the exciter windings. When the generator is started, residual magnetism in the four rotating poles induces a current in the stator which then generates an even larger current in the exciter windings. This mutual build up of current in the four rotating poles and in the exciter windings quickly reaches the saturation point of the capacitor(s) and a regulated energy field is then maintained in the stator. At the same time, this regulated field produces a steady voltage in the stator windings which can then be drawn off the generator's AC terminals to operate AC equipment. The generator is a single-phase, re-connectable 120 volt AC two-wire at 60 hertz, or 115 volt AC two-wire or 230 volt AC two-wire at 50 hertz. Refer to the SPECIFICATIONS section of this manual for generator ratings. The generator's data plate gives the voltage, current and frequency rating of the generator. An AC wiring decal is affixed to the inside of the louvered cover at the generator end. A diagram of the various AC voltage connections is provided on the decal.

Circuit Breaker

A circuit breaker is installed on all single phase WESTERBEKE generators. This circuit breaker will automatically disconnect generator power in case of an electrical overload. The circuit breaker can be manually shut off when servicing the generator to ensure that no power is coming into the boat.

NOTE: This circuit breaker is available as a WESTERBEKE add-on kit for earlier model generators; contact your WESTERBEKE dealer.

60 Hz - 5.0 KW Circuit Breaker Part Number 42705

50 Hz - 4.0 KW Circuit Breaker Part Number 42704

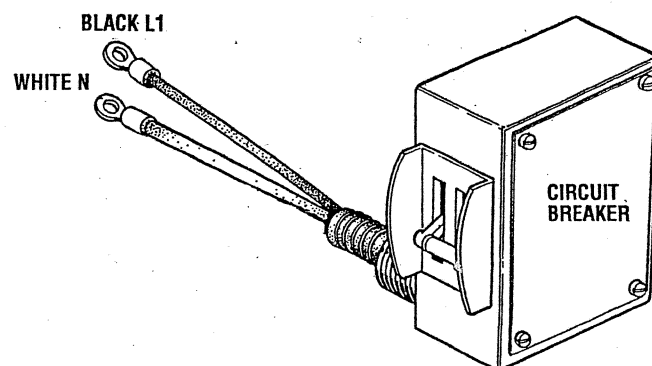

GENERATOR INTERNAL WIRING SCHEMATIC

A. ROTATING FIELD/AUXILIARY WINDINGS WITH DIODES.

B. MAIN STATOR WINDINGS.

C. EXCITER WINDINGS AND CAPACITOR(S).

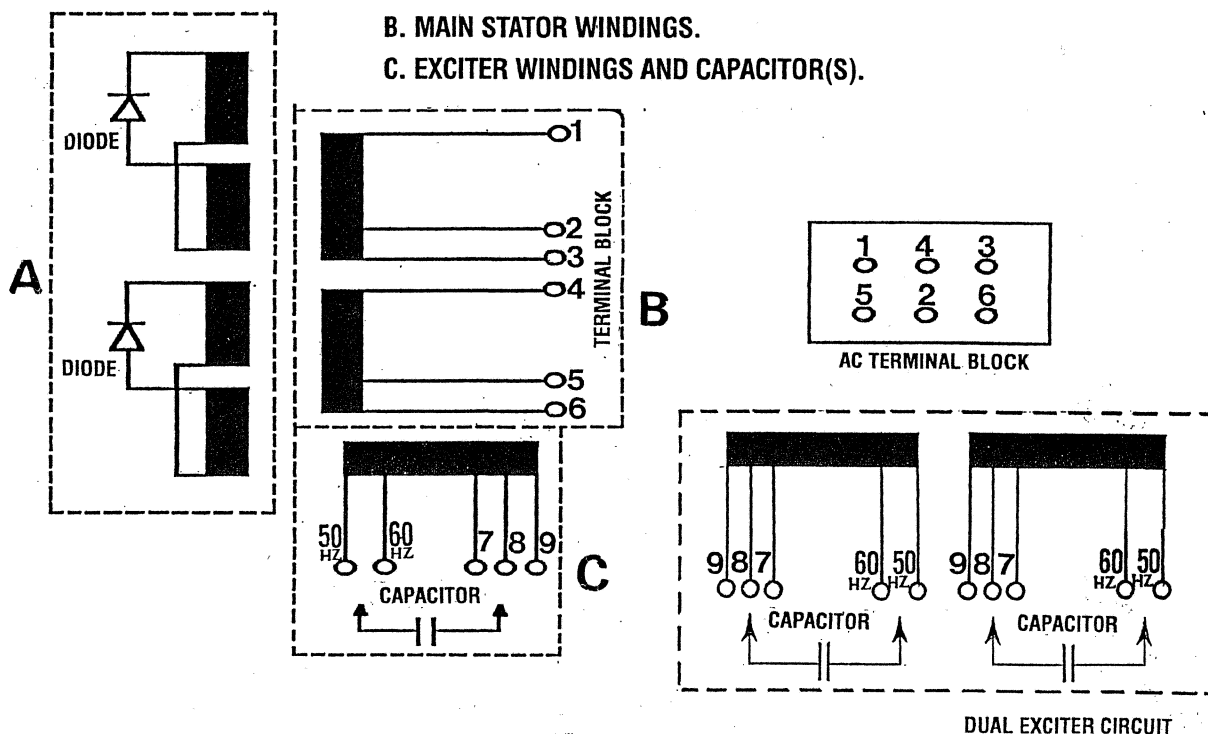

BC GENERATOR SINGLE PHASE

NOTE: WESTERBEKE recommends that the following generator tests and adjustments be performed by a qualified technician.

SINGLE EXCITER NO-LOAD VOLTAGE ADJUSTMENT

1. Remove the louvered metal plate, at the back of the generator, covering the AC terminal connections and the capacitor(s).
2. Start the generator and allow it to run for approximately five minutes so the engine can warm up. Make sure the generator is operating without any equipment drawing AC current from the generator (that is, shut off all electrical appliances). Make sure the engine's speed (Hertz) is correct. Refer to the DC Wiring Diagram for the ECU P8 connection change.
3. Referring to the AC load connections diagram below, check the generator's no-load voltage by measuring the voltage across the neutral lead and the hot lead with a volt meter. Make sure you record this reading. The generator's no-load voltage is 115 - 124 volts at 60.5 - 61.5 Hertz. If the voltage output is higher or lower than specified, proceed.

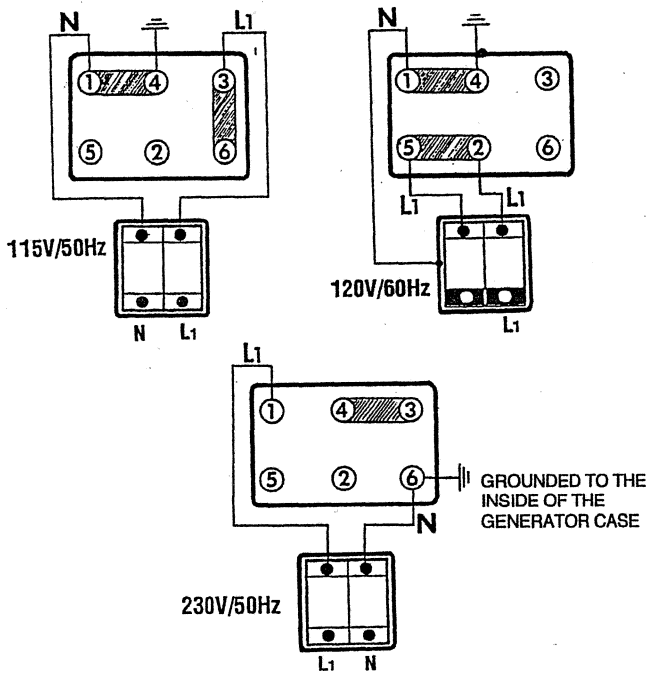

4. Shut off the generator. Make sure the correct Hertz lead (60 Hertz #6, or 50 Hertz #5) is plugged into the capacitor(s).

WARNING: Capacitors must be discharged before handling as they store electricity and can pack a potentially lethal charge even when disconnected from their power source.

NOTE: Simply cross the capacitor's two terminals with an insulated (plastic handle) screwdriver. This will discharge any excess electricity.

WARNING: Do not attempt to make a no-load voltage adjustment while the generator is operating. The capacitor can produce a 400-500 volt charge. Touching any wiring can produce a severe electrical shock. In addition, attempting to make a no-load voltage adjustment while the generator is operating could cause your fingers to be caught in the generator's rotor.

5. There are three plugs grouped for the right capacitor terminal, #7, #8, and #9. If the generator's no-load voltage is low, then disconnect the lower numbered plug and connect the plug with the next higher number. If the generator's no-load voltage is high, then disconnect the higher numbered plug and connect the plug with the next lower number. Note that the plug presently connected to this terminal may be any one of the three plugs available.
6. If the generator's no-load voltage cannot be adjusted because the voltage needs to be increased and the highest numbered plug is already connected to the right terminal, or the voltage needs to be lowered and the lowest numbered plug is connected, refer to the WESTERBEKE BC Generator Troubleshooting Guide).

WARNING: Make certain the insulating covers on the unused leads are in place and are NOT in contact with each other or in contact with the generator's housing.

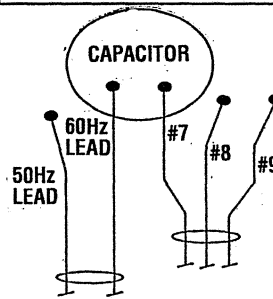

NOTE: THE #7 WIRE IS SHOWN CONNECTED AS A DEMONSTRATION OF HOW THESE CONNECTIONS CAN BE MADE.

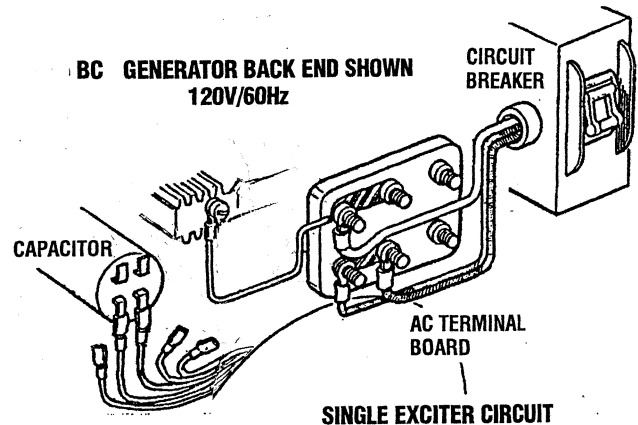

BC GENERATOR SINGLE PHASE

NOTE: WESTERBEKE recommends that the following generator tests and adjustments be performed by a qualified technician.

DUAL EXCITER CIRCUIT MODEL

These generators have dual Hertz and no-load voltage adjustment connectors at each capacitor. There are five connectors available for each capacitor. Two connectors are for Hertz selection, 60 Hertz or 50 Hertz, and three connectors, #7, #8, and #9, are for no-load voltage adjustment.

When making Hertz change or no-load voltage adjustments proceed as follows:

1. Shut the generator down.
2. Select the appropriate Hertz connection to plug into each capacitor #60, 60 Hertz, 1800 RPM or #50 Hertz, 1500 RPM. The three other connectors at each capacitor, #7, #8, and #9, will have an effect on the no-load voltage produced by the generator. One connector from each group can be plugged into each capacitor. No-load voltage will increase or decrease approximately 8-10 AC volts between connectors used in any pair combination to achieve the prescribed no-load voltage as illustrated.

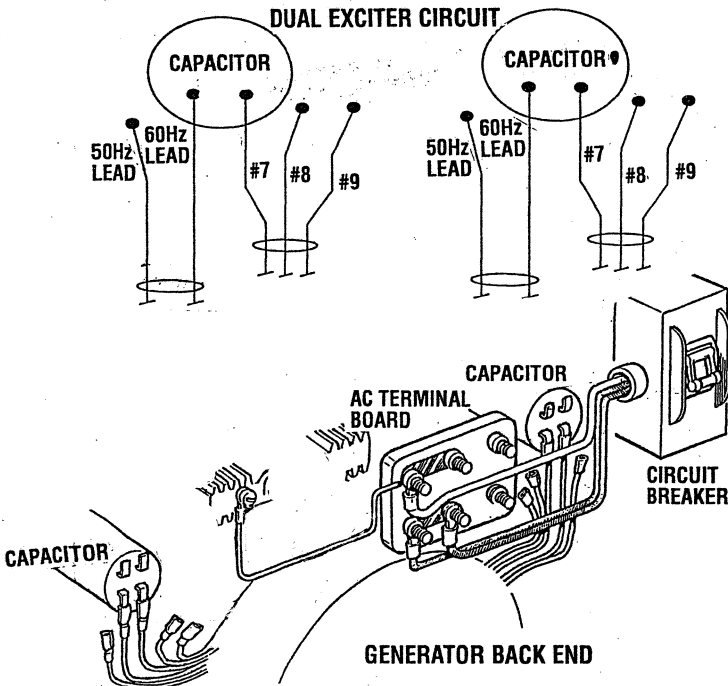

NOTE: When changing Hertz produced by the generator, reference the DC Wiring Diagram for the ECU P8 connection change. The AC output connections on the terminal blocks **must** be selected for the voltage and Hertz to be produced. The Hertz plug connection at the capacitor **must** be changed for 50 Hertz (#5) or 60 Hertz (#6). The frame ground wire **must** be moved when changing from 115 volts, 50 Hertz to 230 volts, 50 Hertz.

WARNING: Capacitors must be discharged before handling as they store electricity and can pack a potentially lethal charge even when disconnected from their power source.

NOTE: Simply cross the capacitor's two terminals with an insulated (plastic handle) screwdriver. This will discharge any excess electricity.

Shore Power Connections

If the installer connects shore power to the vessel's AC circuit, this must be done by means of the Shore Power Transfer Switch. Set the transfer switch shown in the diagrams to the OFF position. This switch prevents simultaneous connection of shore power to generator output.

CAUTION: Damage to the generator can result if utility shore power and generator power are connected at the same time. This type of generator damage is not covered under the warranty; it is the installer's responsibility to make sure all AC connections are correct.

120 Volt/60 Hertz Three Wire Configuration

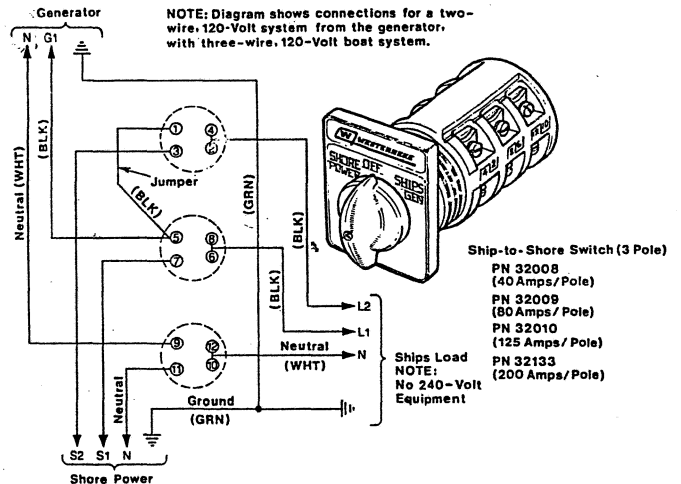

230 Volt/50 Hertz Two Wire Configuration

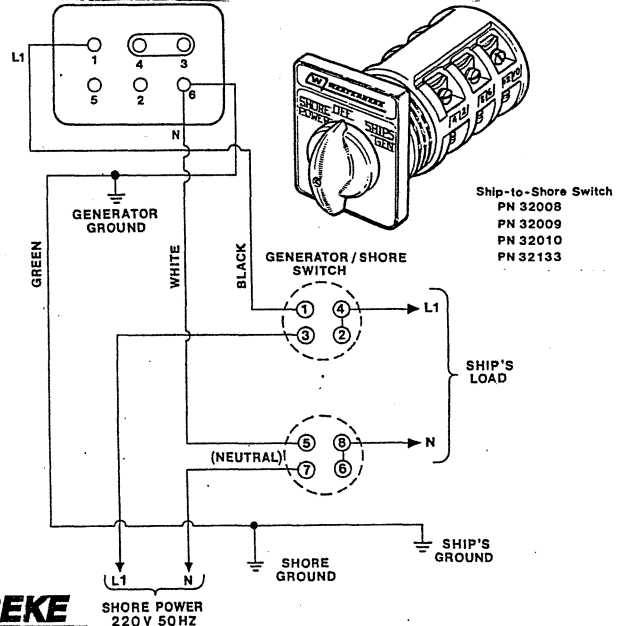

BC GENERATOR SINGLE PHASE

NOTE: WESTERBEKE recommends that the following generator tests and adjustments be performed by a qualified technician.

INTEGRAL CONTROLLER (I.C.)

The Integral Controller (I.C.) is an encapsulated, solid-state unit that supplies a DC charging voltage to the generator's starting battery while the generator is opening.

Charging Voltage: 13.0 - 14.0 volts DC
Charging Amperage: 0 - 10- amps DC

A separate group of stator windings supplies AC voltage to a bridge rectifier which converts the AC current to supply the I.C. unit. The I.C. unit senses the needs of the starting battery and supplies a DC charge when one is needed. If you suspect that the I.C. unit is faulty (that is, if the battery's charge is low), check the charging circuit and its components as described in the following steps. Check all connections for cleanliness and tightness including the ground before replacing the I.C. unit.

NOTE: When the generator is first started, the I.C. unit will produce a low charging rate. This charging rate will rise as the generator is operated.

The Integral Controller is mounted inside the generator housing in the 12:00 position.

Testing the Battery Charging Circuit

1. Bridge Rectifier

Normal AC voltage running to the rectifier (while the engine is operating at 1800 rpm) is measured across the two AC connections on the bridge rectifier. (As illustrated).

AC voltage running to the bridge rectifier (approximate):

No-load off the generator 16.0 volts AC
Full-load off the generator 17.5 volts AC

Normal DC voltage running out of the rectifier (in volts DC) is measured across the two DC connections of the bridge rectifier; that is + and -.

DC voltage running from the bridge rectifier (approximate):

No-load off the generator 17.0 volts DC
Full-load off the generator 18.5 volts DC

2. AC winding: 0.14 ohm

Lift the two AC wire leads off the bridge rectifier and measure, the resistance between these two leads with an ohmmeter. It should measure 0.14 ohm. No continuity should exist between these two leads and the ground or the main AC stator windings.

3. Testing the Bridge Rectifier (meter used - FLUKE multimeter)

- A. Set the meter on Ohms scale.
- B. Connect the positive (+) lead from the meter to point #4. Taking the negative (-) lead, momentarily touch points #1, #2, #3, and #5. There should be no Ohm value registered on the meter.
- C. Remove the positive (+) lead from point #4 and connect the negative (-) lead to it. Momentarily touch points #1, #2 and #3. the Ohm meter should register an arbitrary Ohm value at each point it touches.
- D. Leaving the negative (-) lead on point #4, touch point #5 with the positive (+) lead. The meter should register no Ohm value.
- E. Place the positive (+) lead on point #1 and the negative (-) lead on point #3. The meter again should register no Ohm value. Reverse these connections and the meter should register no Ohm value.

If the rectifier fails any of the previous tests B through E, replace the rectifier as it is defective.

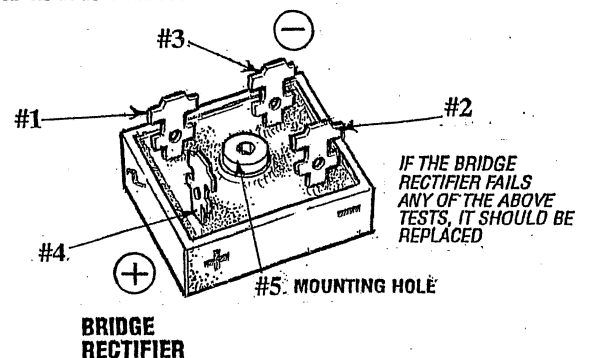
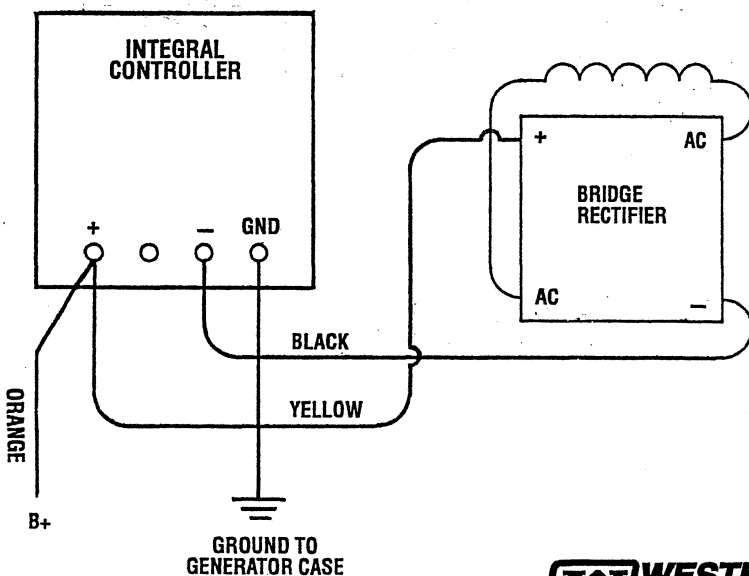
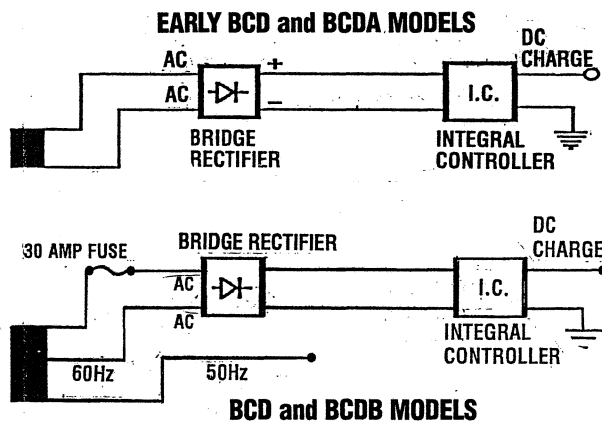

DOMESTIC HOT WATER HEATER CONNECTIONS

DESCRIPTION

Once the Heater By-Pass connection is installed on the engine, plumbing of the engine antifreeze coolant can be made to the water heater. The water heater should be mounted in a convenient location either in a high or low position in relation to the engine so that the connecting hoses from the heater to the engine can run in a reasonably direct line without any loops which might trap air.

INSTALLATION

Follow the steps as illustrated below. Remove the upper and lower thermostat housing. This will allow access to remove the existing by-pass fixture as shown in STEP 1. Install the Heater By-Pass as shown in STEP 2.

The hose spuds on the Heater By-Pass are for 3/8" I.D. hose, to connect to 5/8" I.D. hose, use the hose adapters.

STEP 1: UN-BOLT AND REMOVE THE UPPER AND LOWER THERMOSTAT HOUSINGS AS ONE ASSEMBLY. REMOVE THE EXISTING BY-PASS FIXTURE.

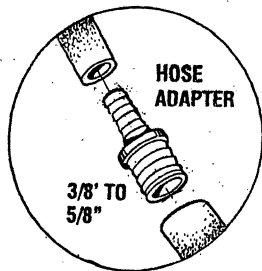
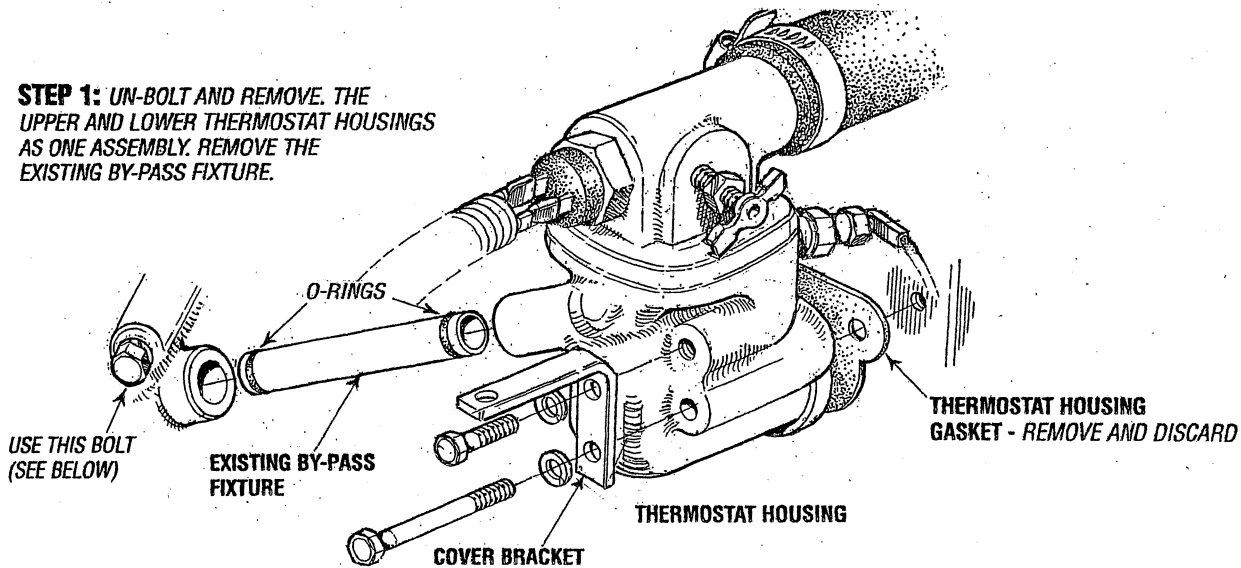

STEP 2: ATTACH THE TWO SEALING O-RINGS TO THE WATER HEATER BY-PASS AND ASSEMBLE AS ILLUSTRATED.

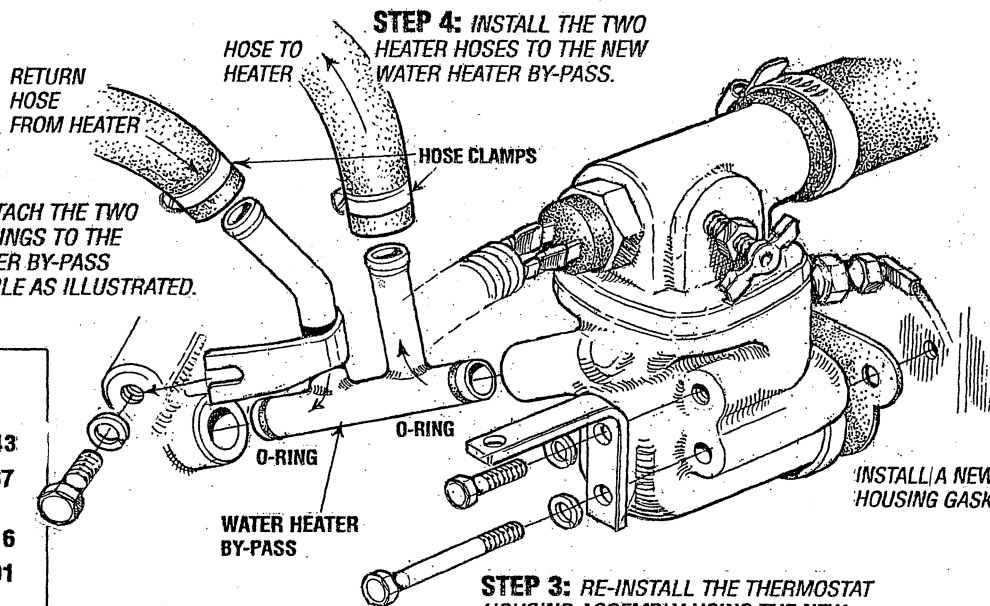

STEP 4: INSTALL THE TWO HEATER HOSES TO THE NEW WATER HEATER BY-PASS.

STEP 3: RE-INSTALL THE THERMOSTAT HOUSING ASSEMBLY USING THE NEW GASKET.

PARTS LISTING

HEATER BY-PASS	PN 042743
SEALING O-RING (2)	PN 036937
THERMOSTAT LOWER HOUSING GASKET	PN 037016
HOSE ADAPTERS (2)	PN 302391
THERMOSTAT HOUSING GASKET	PN 036956

DOMESTIC HOT WATER HEATER CONNECTIONS

WATER HEATER INSTALLATIONS

Once the Heater By-Pass connection is installed on the engine, plumbing of the engine antifreeze coolant can be made to the water heater. The water heater should be mounted in a convenient location either in a high or low position in relation to the engine so that the connecting hoses from the heater to the engine can run in a reasonably direct line without any loops which might trap air.

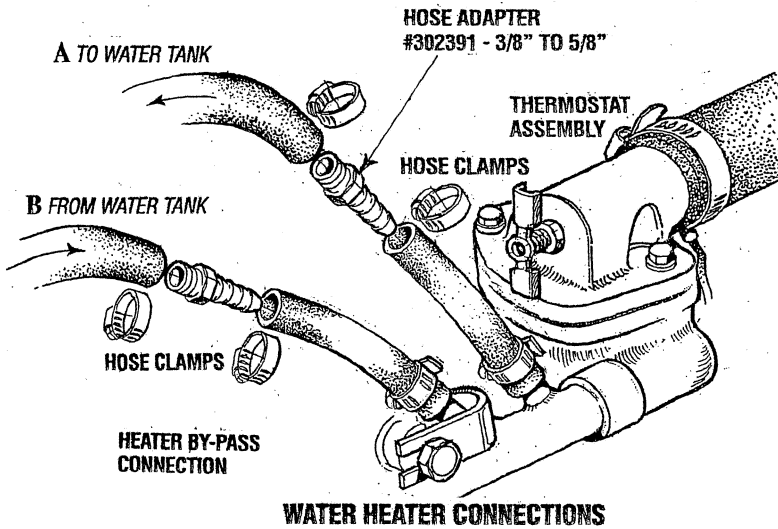

Using the Heater By-Pass connection, install hoses A and B as illustrated below. Use the hose adapters (PN 302391) to increase the hose size from 3/8" to 5/8".

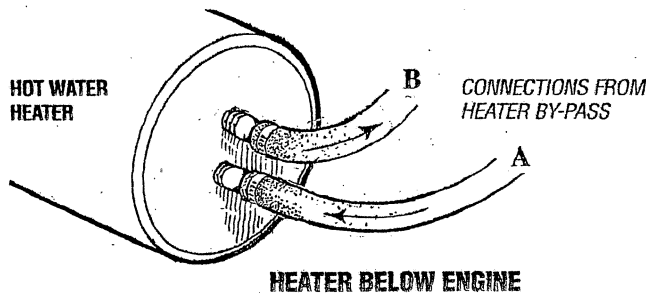

FILLING THE COOLING SYSTEM

Fill the engine's cooling system with antifreeze thru the pressure cap operating on the exhaust manifold. Start the engine and monitor the coolant until good circulation is noted. Fill the manifold and install the pressure cap. Add antifreeze to the coolant recovery tank (mark). The engine's antifreeze circuit with its hot water heater should now be fully functional.

HEATER ABOVE THE ENGINE

When the water heater is located above the engine, a remote expansion tank is required. Install the expansion tank in a convenient location above the water heater.

NOTE: The expansion tank replaces the standard plastic recovery tank and will now serve as the systems check point and fillpoint.

As shown in the illustration, a single hose is teed into the fitting at connection B on the water heater. That hose must rise continuously to the expansion tank. (This will allow any air to rise to the tank and be expelled).

Remove the plastic coolant recovery tank that is no longer needed. Remove its attachment fitting from the exhaust manifold and plug the opening with a 1/8npt plug.

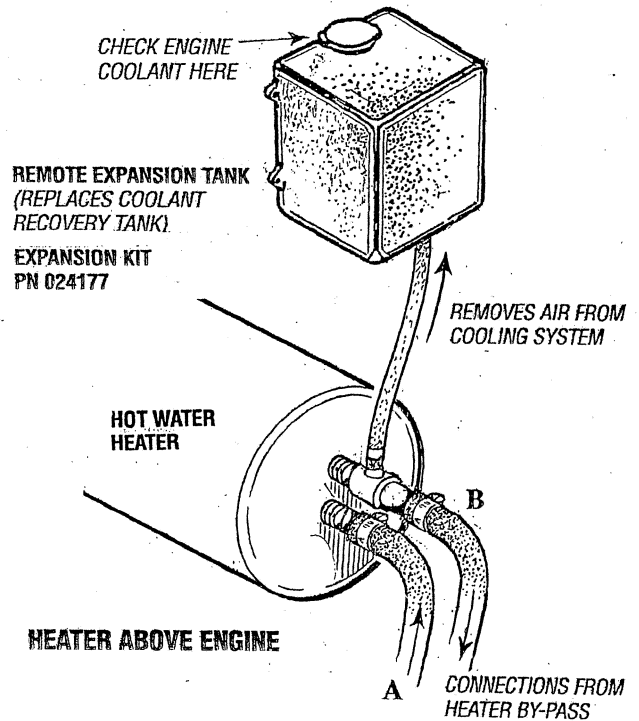

FILLING THE COOLANT SYSTEM (REMOTE TANK)

Fill the engine's cooling system at the pressure cap opening on the engine's water jacketed exhaust manifold. Install the pressure cap and continue filling the system at the remote expansion tank. Fill the tank to about 1/2 full. Start the engine and monitor the coolant level in the remote tank. As air is expelled, add coolant to maintain this level. Once the level is stable and good circulation is felt at both heater hoses, install the pressure cap on the remote tank. When checking the engine coolant level, it is now done at the remote expansion tank.

POWER TAKE OFF SYSTEMS

POWER TAKE OFF ADAPTER

A power take off adapter can be attached to the generator backend. This adapter allows access to the full power of the engine for a variety of hydraulic and electrical accessories.

THE BC GENERATOR MODELS IN THIS MANUAL PRODUCE 9.0 HP. (APPROXIMATE) AT A CONTINUOUS 1800 RPM. THIS HORSEPOWER CAN BE UTILIZED EITHER FOR GENERATOR AC OUTPUT OR FOR EQUIPMENT FROM THE POWER TAKE-OFF.

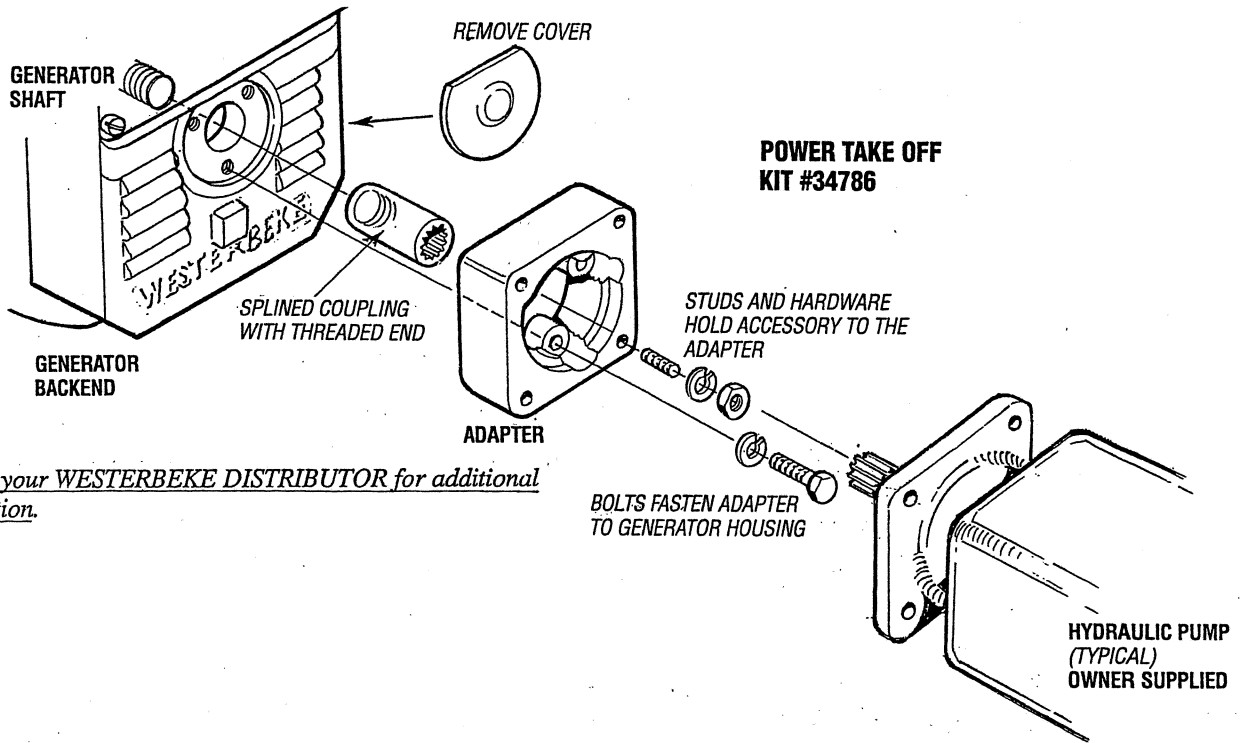

Contact your WESTERBEKE DISTRIBUTOR for additional information.

LAY-UP & RECOMMISSIONING

GENERAL

Many owners rely on their boatyards to prepare their craft, including engines and generators, for lay-up during the off-season or for long periods of inactivity. Others prefer to accomplish lay-up preparation themselves.

The procedures which follow will allow you to perform your own lay-up and recommissioning, or you may use them as a check list if others do the procedures.

These procedures should afford your engine protection during a lay-up and also help familiarize you with the maintenance needs of your engine.

If you have any questions regarding lay-up procedures, call your local servicing dealer; he will be more than willing to provide assistance.

Propeller Shaft Coupling [Propulsion Engine]

The transmission and propeller half couplings should always be opened up and the bolts removed when the boat is hauled out of the water or moved from land to water, and during storage in the cradle. The flexibility of the boat often puts a severe strain on the propeller shaft or coupling or both, while the boat is taken out or put in the water. In some cases, the shaft has actually been bent by these strains. This does not apply to small boats that are hauled out of the water when not in use, unless they have been dry for a considerable period of time.

Fresh Water Cooling Circuit [Propulsion Engine]

A 50-50 solution of antifreeze and distilled water is recommended for use in the coolant system at all times. This solution may require a higher concentration of antifreeze, depending on the area's winter climate. Check the solution to make sure the antifreeze protection is adequate.

Should more antifreeze be needed, drain an appropriate amount from the engine block and add a more concentrated mixture. Operate the engine to ensure a complete circulation and mixture of the antifreeze concentration throughout the cooling system. Now recheck the antifreeze solution's strength.

Lubrication System

With the engine warm, drain all the engine oil from the oil sump. Remove and replace the oil filter and fill the sump with new oil. Use the correct grade of oil. Refer to the *ENGINE LUBRICATING OIL* pages in this manual for the oil changing procedure. Run the engine and check for proper oil pressure and make sure there are no leaks.

⚠ CAUTION: Do not leave the engine's old engine oil in the sump over the lay-up period. Lubricating oil and combustion deposits combine to produce harmful chemicals which can reduce the life of your engine's internal parts.

Fuel System [Gasoline]

Top off your fuel tanks with *unleaded* gasoline of 89 octane or higher. A fuel conditioner such as *Sta-Bil* gasoline stabilizer should be added. Change the element in your gasoline/water separator and clean the metal bowl. Re-install and make certain there are no leaks. Clean up any spilled fuel.

Fuel System [Diesel]

Top off your fuel tanks with No. 2D diesel fuel. Fuel additives should be added prior to topping off to ensure they mix with the fuel being added and fuel still in the tank. Additives, such as Bio-bor and Diesel Kleen + Cetane Boost should be added at this time to control bacteria growth and condition the fuel. Care should be taken that the additives used are compatible with the primary fuel filter/water separator used in the system. Change the element in your primary fuel filter/water separator clean the separator sediment bowl.

Change the fuel filter elements on the engine and bleed the fuel system, as needed. Start the engine and allow it to run for 5 – 10 minutes to make sure no air is left in the fuel system. Check for any leaks that may have been created in the fuel system during this servicing, correcting them as needed. Operating the engine for 5 – 10 minutes will help allow movement of the treated fuel through the injection equipment on the engine.

Raw Water Cooling Circuit

Close the through-hull seacock. Remove the raw water intake hose from the seacock. Place the end of this hose into a five gallon bucket of clean fresh water. Before starting the engine, check the zinc anode found in the primary heat exchanger on the engine and clean or replace it as required, and also clean any zinc debris from inside the heat exchanger where the zinc anode is located. Clean the raw water strainer.

Start the engine and allow the raw water pump to draw the fresh water through the system. When the bucket is empty, stop the engine and refill the bucket with an antifreeze solution slightly stronger than needed for winter freeze protection in your area.

Start the engine and allow all of this mixture to be drawn through the raw water system. Once the bucket is empty, stop the engine. This antifreeze mixture should protect the raw water circuit from freezing during the winter lay-up, as well as providing corrosion protection.

Remove the impeller from your raw water pump (some antifreeze mixture will accompany it, so catch it in a bucket). Examine the impeller. Acquire a replacement, if needed, and a cover gasket. Do not replace the impeller (into the pump) until recommissioning, but replace the cover and gasket.

LAY-UP & RECOMMISSIONING

Starter Motor

Lubrication and cleaning of the starter drive pinion is advisable, if access to the starter permits its easy removal. Make sure the battery connections are shut off before attempting to remove the starter. Take care in properly replacing any electrical connections removed from the starter.

Cylinder Lubrication [Diesel]

If you anticipate a long lay-up period (12 months or more) WESTERBEKE recommends removal of the glow plugs for access to the cylinders. Squirt some Marvel Mystery Oil into the cylinder walls. Rotate the engine crankshaft by hand two revolutions and re-install the glow plugs.

If your engine does not have glow plugs, the injectors will have to be removed. Be sure to have replacement sealing washers for the injectors and return fuel line as needed.

Intake Manifold [Gasoline]

Clean the filter screen in the flame arrester, and place a clean cloth lightly soaked in lube oil around the flame arrester to block any opening. Also place an oil-soaked cloth in the through-hull exhaust port. Make a note to remove cloths prior to start-up!

Cylinder Lubrication [Gasoline]

Remove the flame arrester and clean. Operate the engine and spray fogging oil into the intake stalling the engine. This will coat the intake, valves and cylinders with a protecting oil. Reinstall the flame arrester.

NOTE: At re-commissioning, remove the spark plugs and clean and gap them. Rotate the engine by hand two complete revolutions. Re-install the spark plugs and tighten securely and firmly attach the high tension leads.

Batteries

If batteries are to be left on board during the lay-up period, make sure that they are fully charged, and will remain that way, to prevent them from freezing. If there is any doubt that the batteries will not remain fully charged, or that they will be subjected to severe environmental conditions, remove the batteries and store them in a warmer, more compatible environment.

WARNING: Lead acid batteries emit hydrogen, a highly-explosive gas, which can be ignited by electrical arcing or a lighted cigarette, cigar, or pipe. Do not smoke or allow an open flame near the battery being serviced. Shut off all electrical equipment in the vicinity to prevent electrical arcing during servicing.

Transmission [Propulsion Engine]

Check or change the fluid in the transmission as required. Wipe off grime and grease and touch up any unpainted areas. Protect the coupling and the output flange with an anti-corrosion coating. Check that the transmission vent is open. For additional information, refer to the *TRANSMISSION SECTION*.

Spare Parts

Lay-up time provides a good opportunity to inspect your Westerbeke engine to see if external items such as drive belts or coolant hoses need replacement. Check your basic spares kit and order items not on hand, or replace those items used during the lay-up, such as filters and zinc anodes. Refer to the *SPARE PARTS* section of this manual.

Recommissioning

The recommissioning of your Westerbeke engine after a seasonal lay-up generally follows the same procedures as those described in the *PREPARATIONS FOR STARTING* section regarding preparation for starting and normal starts. However, some of the lay-up procedures will need to be counteracted before starting the engine.

1. Remove the oil-soaked cloths from the intake manifold.
2. Remove the raw water pump cover and gasket and discard the old gasket. Install the raw water pump impeller removed during lay-up (or a replacement, if required). Install the raw water pump cover with a new cover gasket.
3. Reinstall the batteries that were removed during the lay-up, and reconnect the battery cables, making sure the terminals are clean and that the connections are tight. Check to make sure that the batteries are fully charged.

CAUTION: Wear rubber gloves, a rubber apron, and eye protection when servicing batteries. Lead acid batteries emit hydrogen, a highly explosive gas, which can be ignited by electrical arcing or a lighted cigarette, cigar, or pipe. Do not smoke or allow an open flame near the battery being serviced. Shut off all electrical equipment in the vicinity to prevent electrical arcing during servicing.

4. Remove the spark plugs, wipe clean, re-gap, and install to proper tightness [gasoline].
5. Check the condition of the zinc anode in the raw water circuit and clean or replace the anode as needed. Note that it is not necessary to flush the antifreeze/fresh water solution from the raw water coolant system. When the engine is put into operation, the system will self-flush in a short period of time with no adverse affects. It is advisable, as either an end of season or recommissioning service, to inspect the area where the zinc is located in the heat exchanger and clear any and all zinc debris from that area.
6. Start the engine in accordance with procedures described in the *PREPARATIONS FOR STARTING* section of this manual.

SUGGESTED SPARE PARTS

CONTACT YOUR WESTERBEKE DEALER FOR SUGGESTIONS AND ADDITIONAL INFORMATION

WESTERBEKE RECOMMENDS CARRYING ENOUGH ENGINE OIL (YOUR BRAND) FOR AN OIL CHANGE AND A GALLON OF PREMIXED COOLANT.

THERMOSTAT KIT

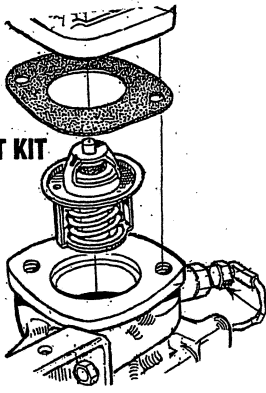

ZINC ANODE

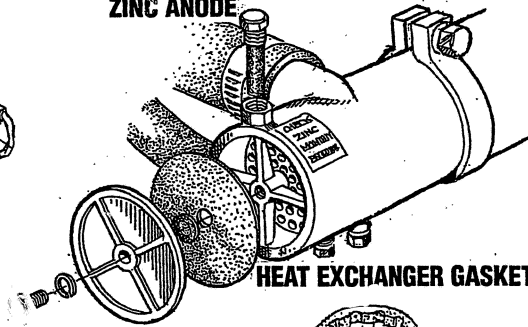

HEAT EXCHANGER GASKET

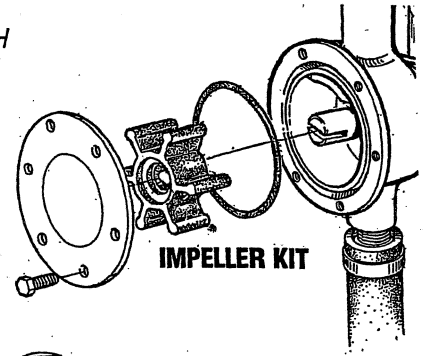

IMPELLER KIT

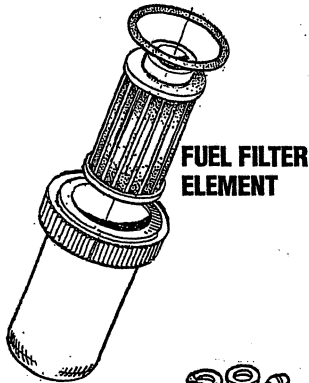

FUEL FILTER ELEMENT

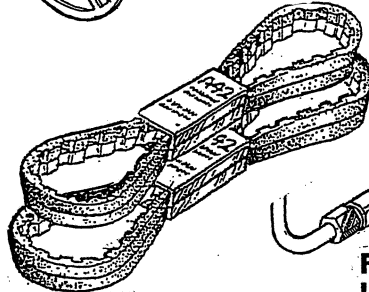

SPARE DRIVE BELTS

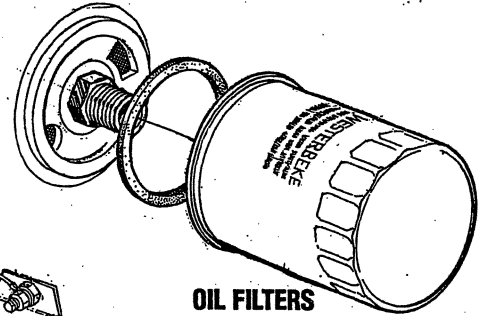

OIL FILTERS

FUEL SYSTEM HARDWARE KIT

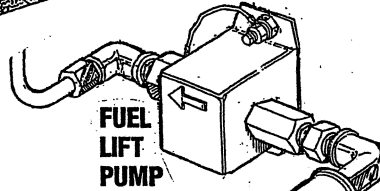

FUEL LIFT PUMP



FUEL INLET PUMP

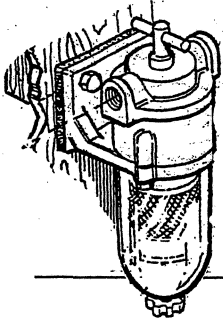

IN-LINE FUEL/WATER FILTER CARTRIDGE

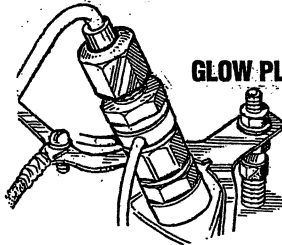

GLOW PLUG

INJECTOR

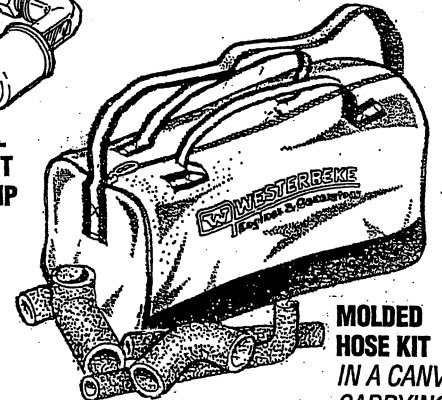

MOLDED HOSE KIT IN A CANVAS CARRYING BAG

SPARE PARTS KITS

WESTERBEKE also offers two Spare Parts Kits, each packaged in a rugged hinged toolbox.

Kit "A" includes the basic spares.

Kit "B" is for more extensive off-shore cruising.

KIT A

- ZINC ANODES
- DRIVE BELTS
- OIL FILTER
- FUEL FILTER
- HEAT EXCHANGER GASKET
- IMPELLER KIT
- FUEL SYSTEM HARDWARE KIT
- FUEL PUMP INLET FILTER

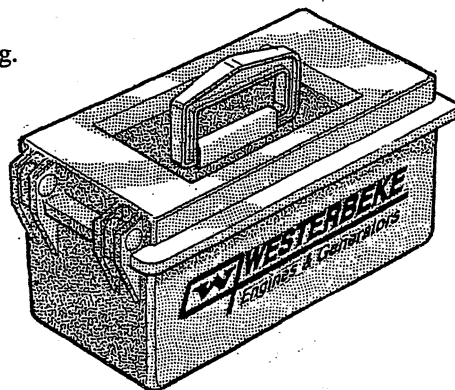

KIT B

- ZINC ANODES
- DRIVE BELTS
- OIL FILTER
- FUEL FILTER
- HEAT EXCHANGER GASKET
- IMPELLER KIT
- INJECTOR
- OVERHAUL GASKET KIT
- GLOW PLUG
- FUEL SYSTEM HARDWARE KIT
- FUEL PUMP INLET FILTER

WESTERBEKE
Engines & Generators

